

UNOPIU'

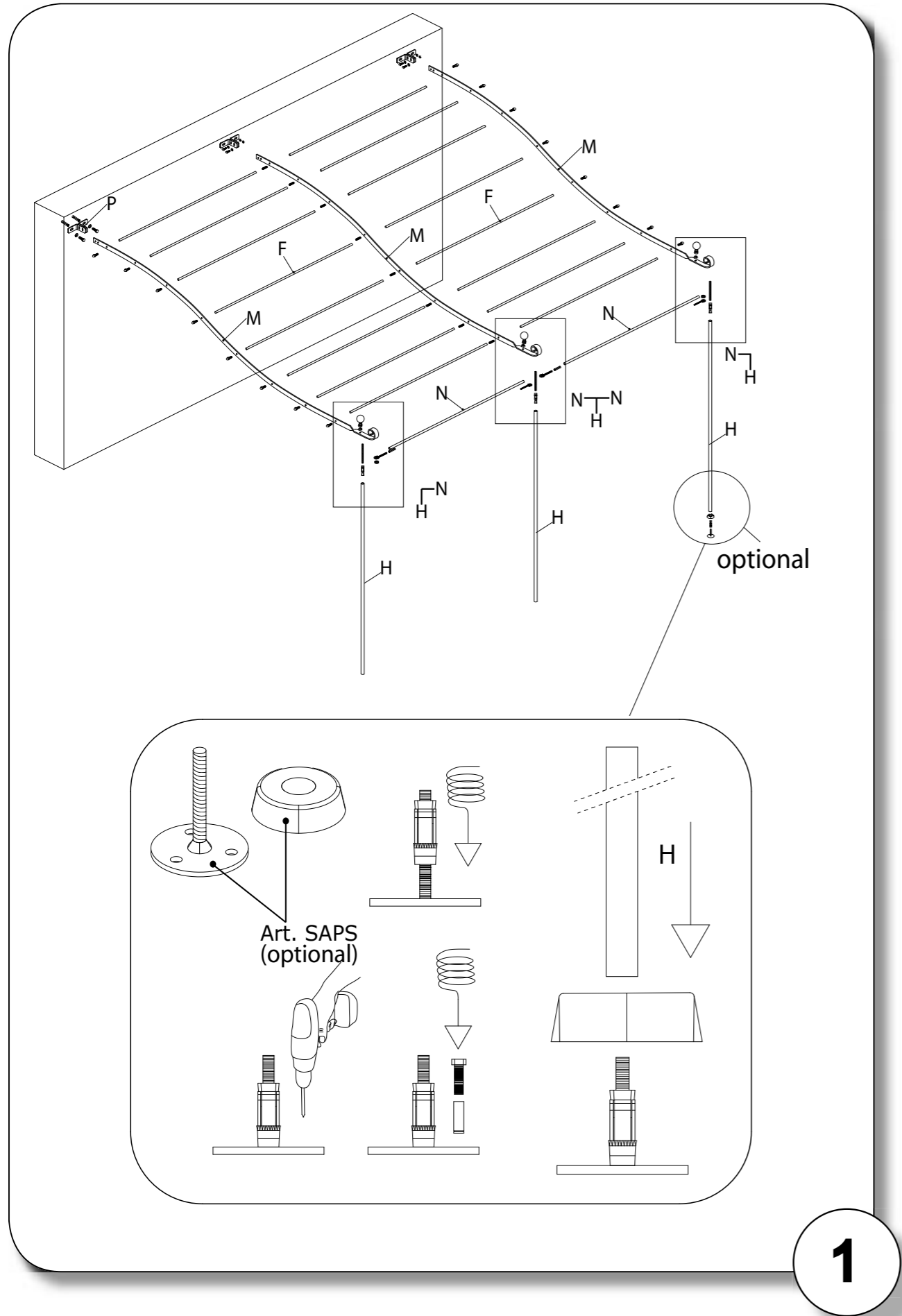

UNOPIU' S.p.A.
S.S. Ortana Km. 14,500
01038 Soriano nel Cimino (VT) - Italia

***Solaire
addossata curva***



1

1

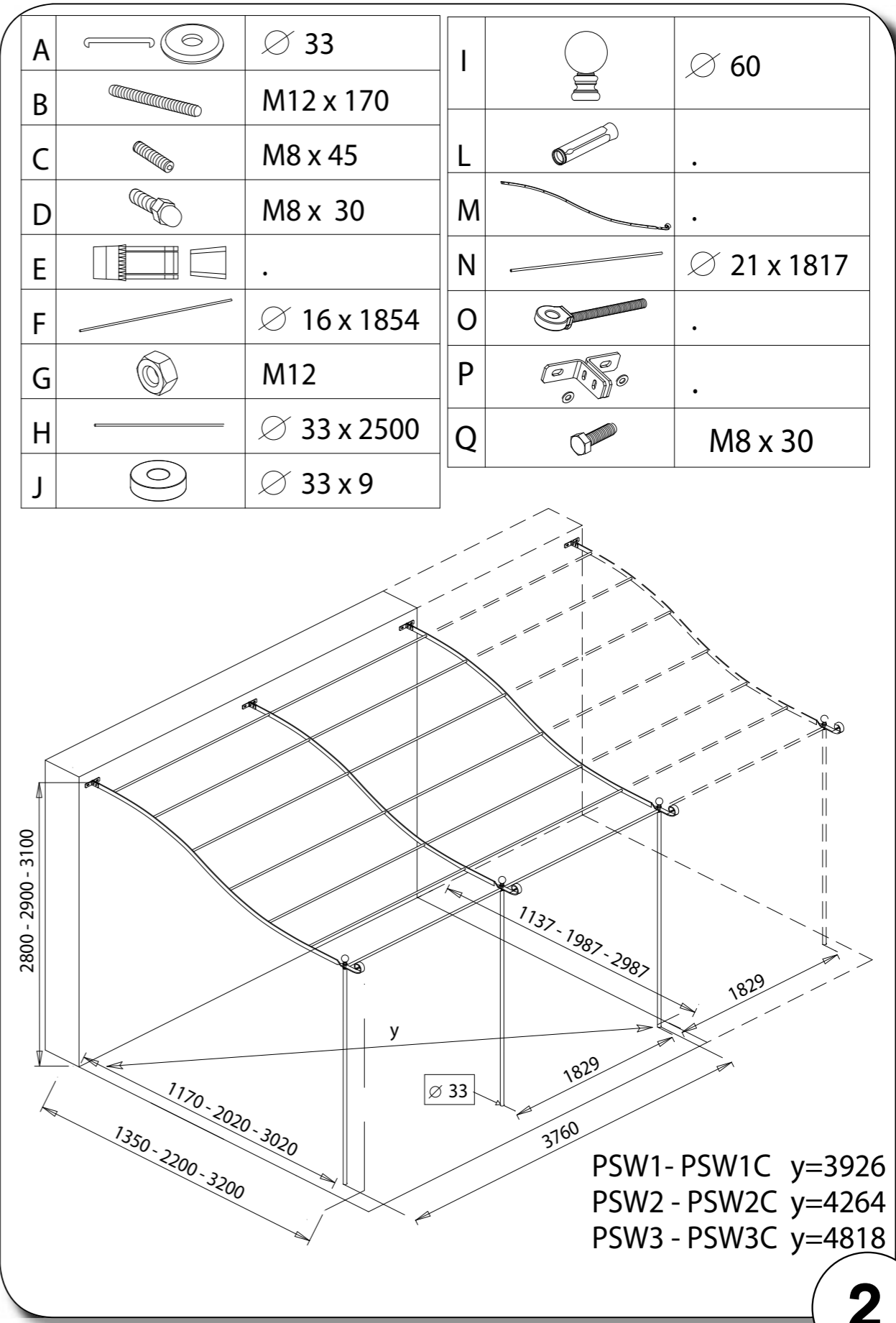

2

3

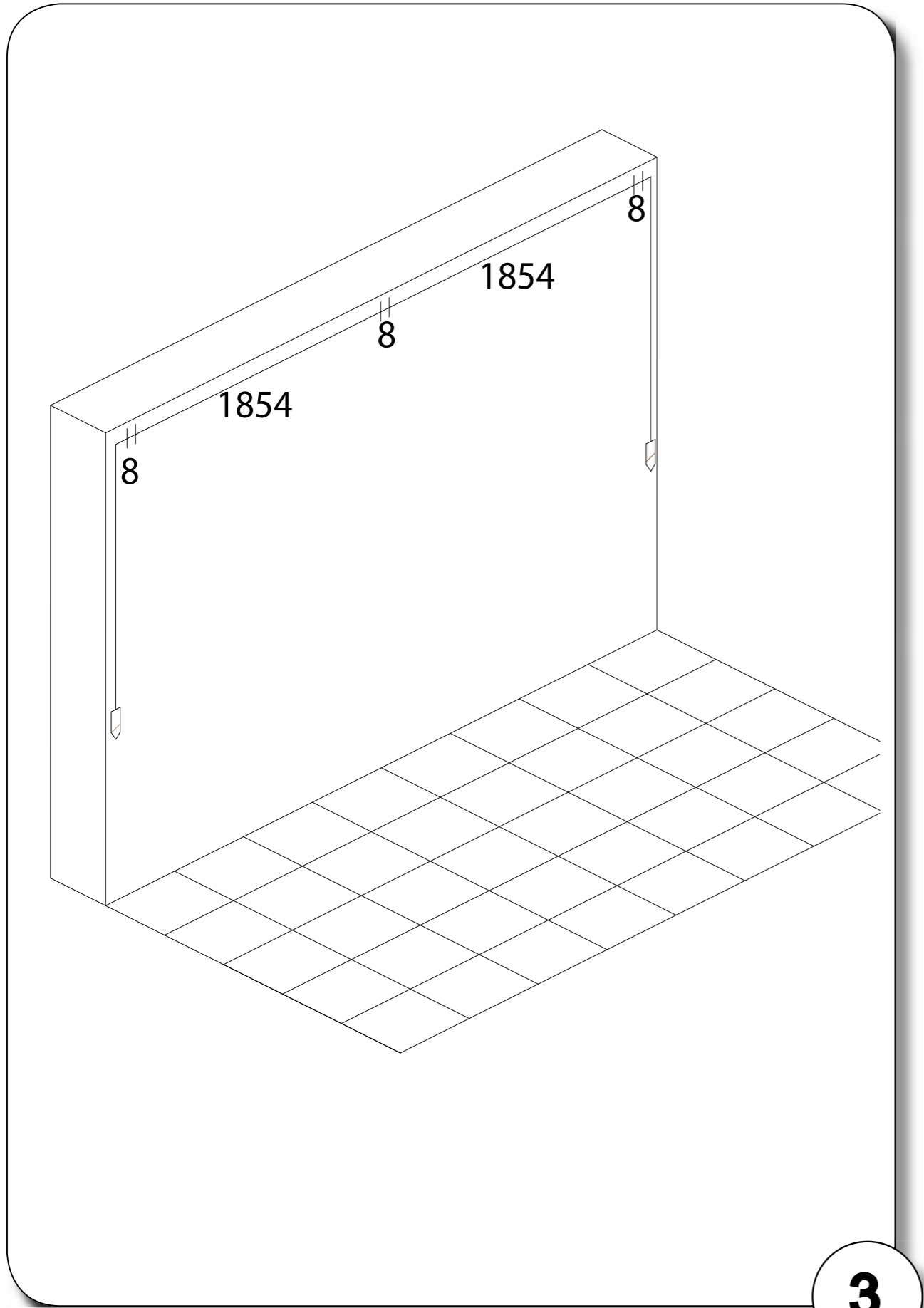

3

4

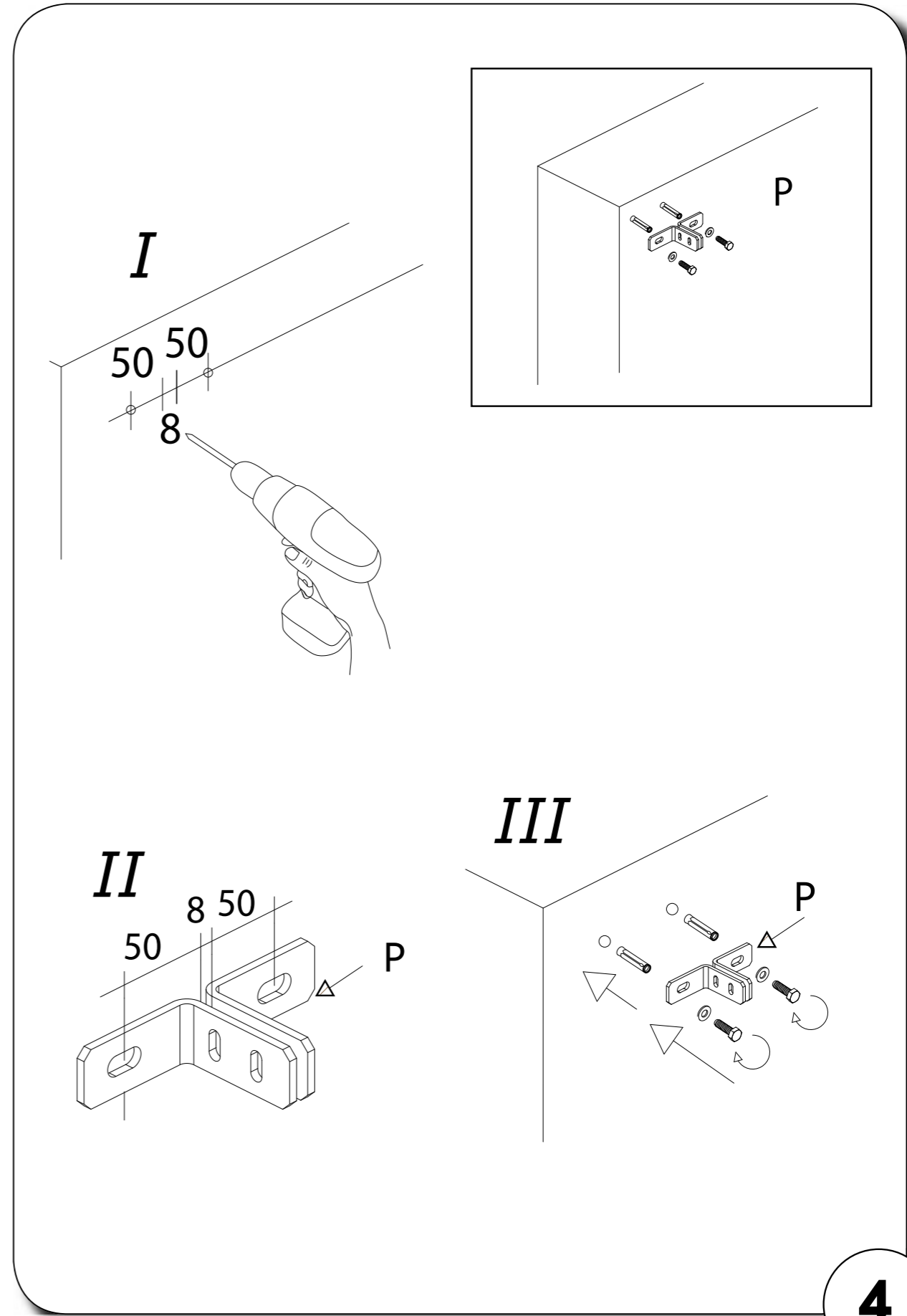

4

X art. PSW1C - PSW1EC
 PSW2C - PSW2EC
 PSW3C - PSW3EC

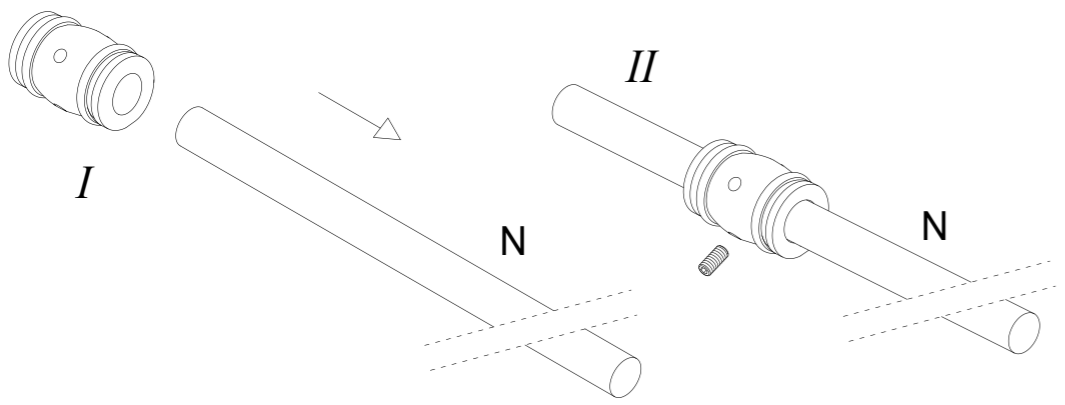
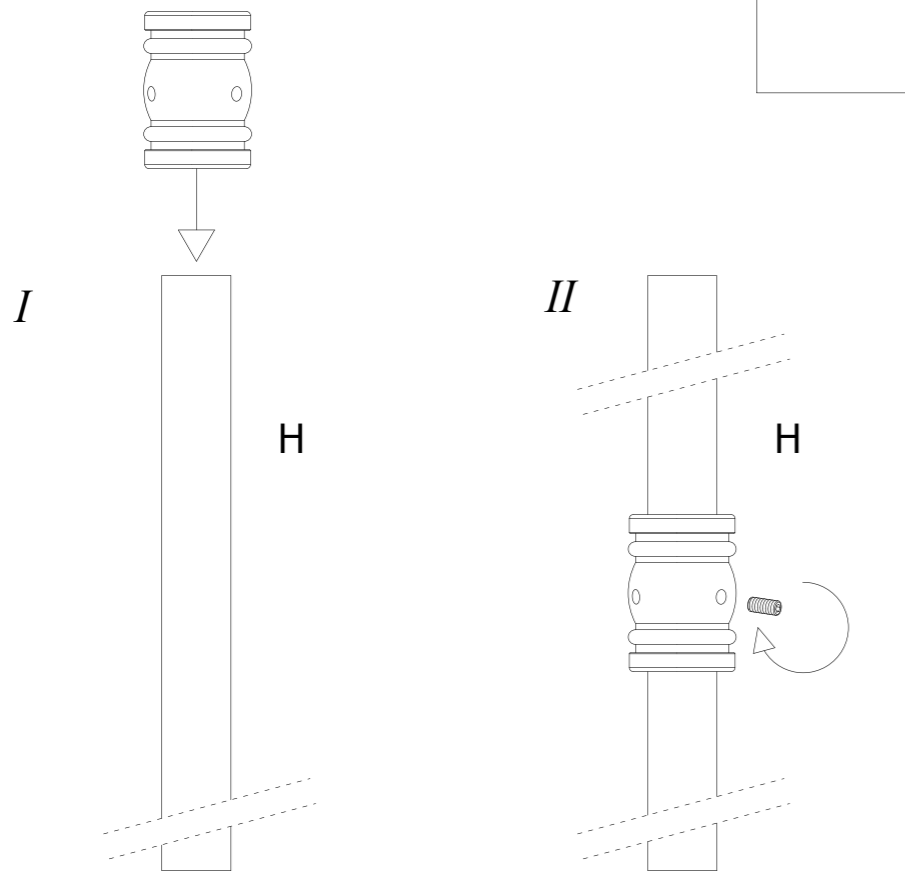
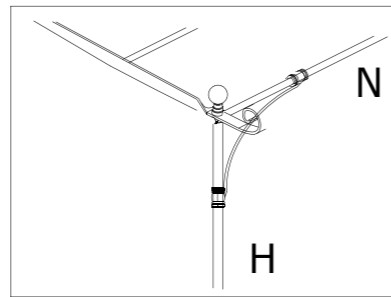

5

5

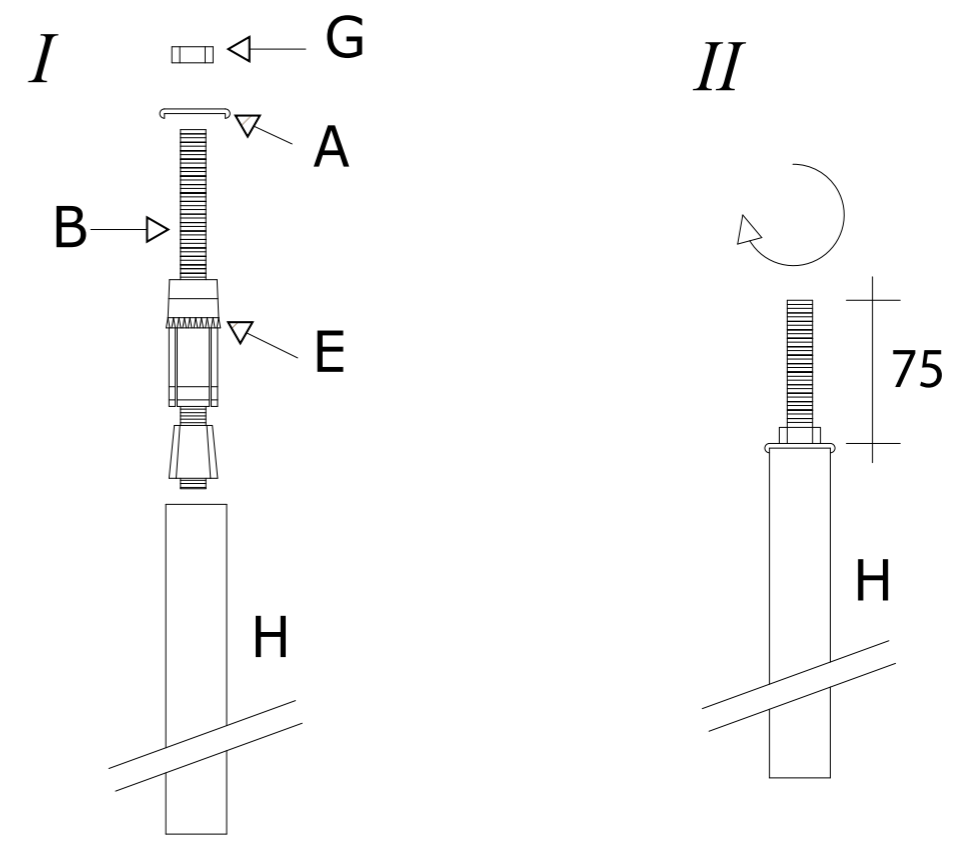
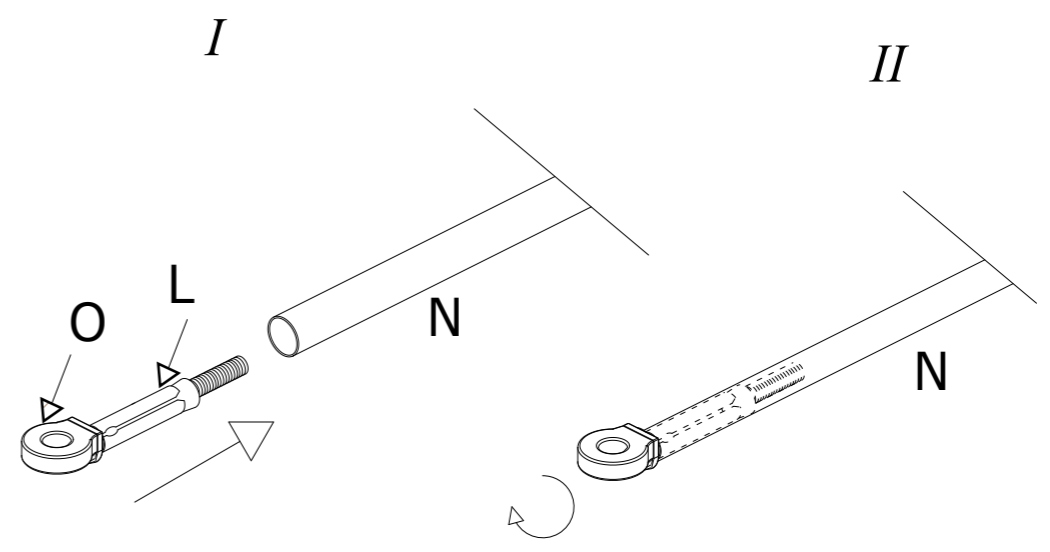

6

6

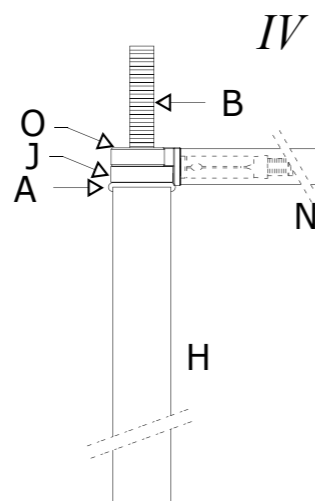
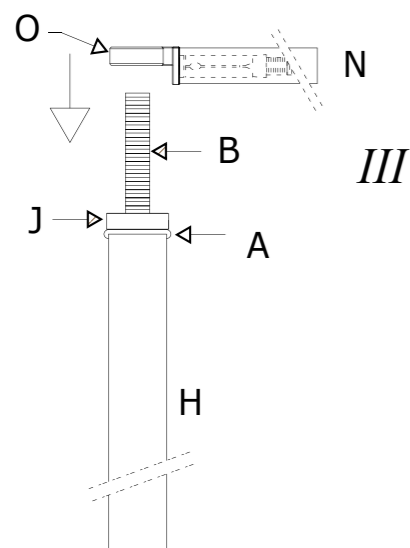
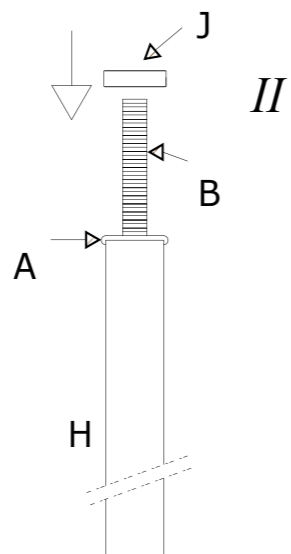
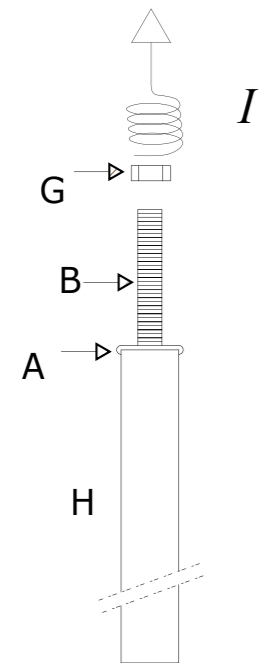
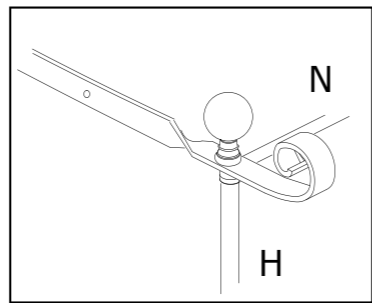
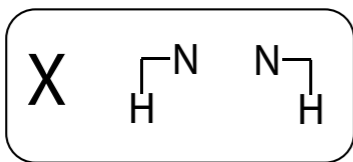

7

7

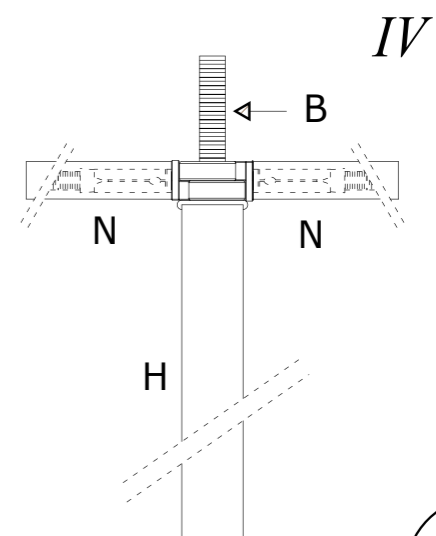
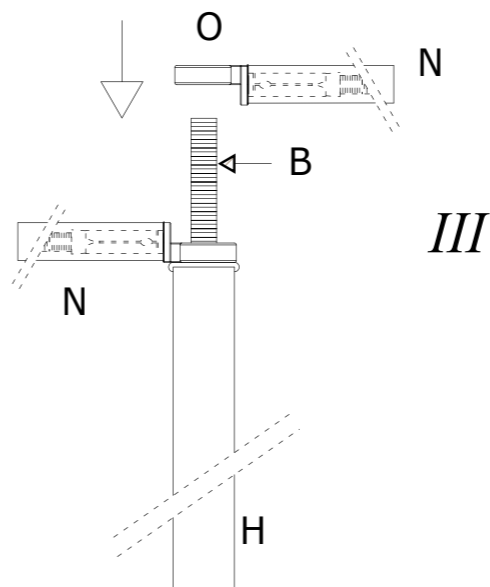
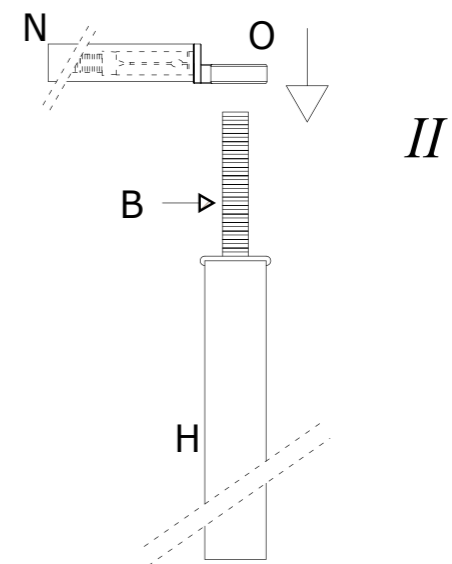
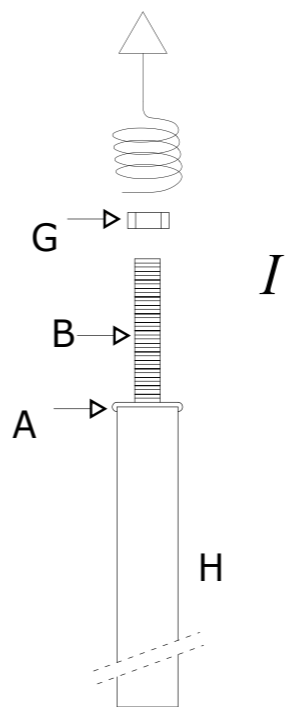
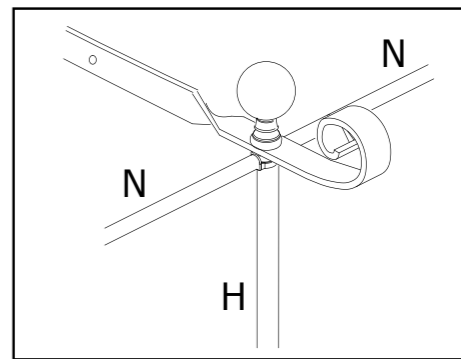
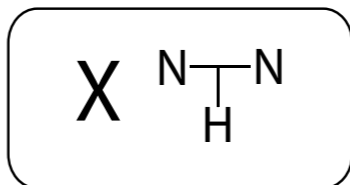

8

8

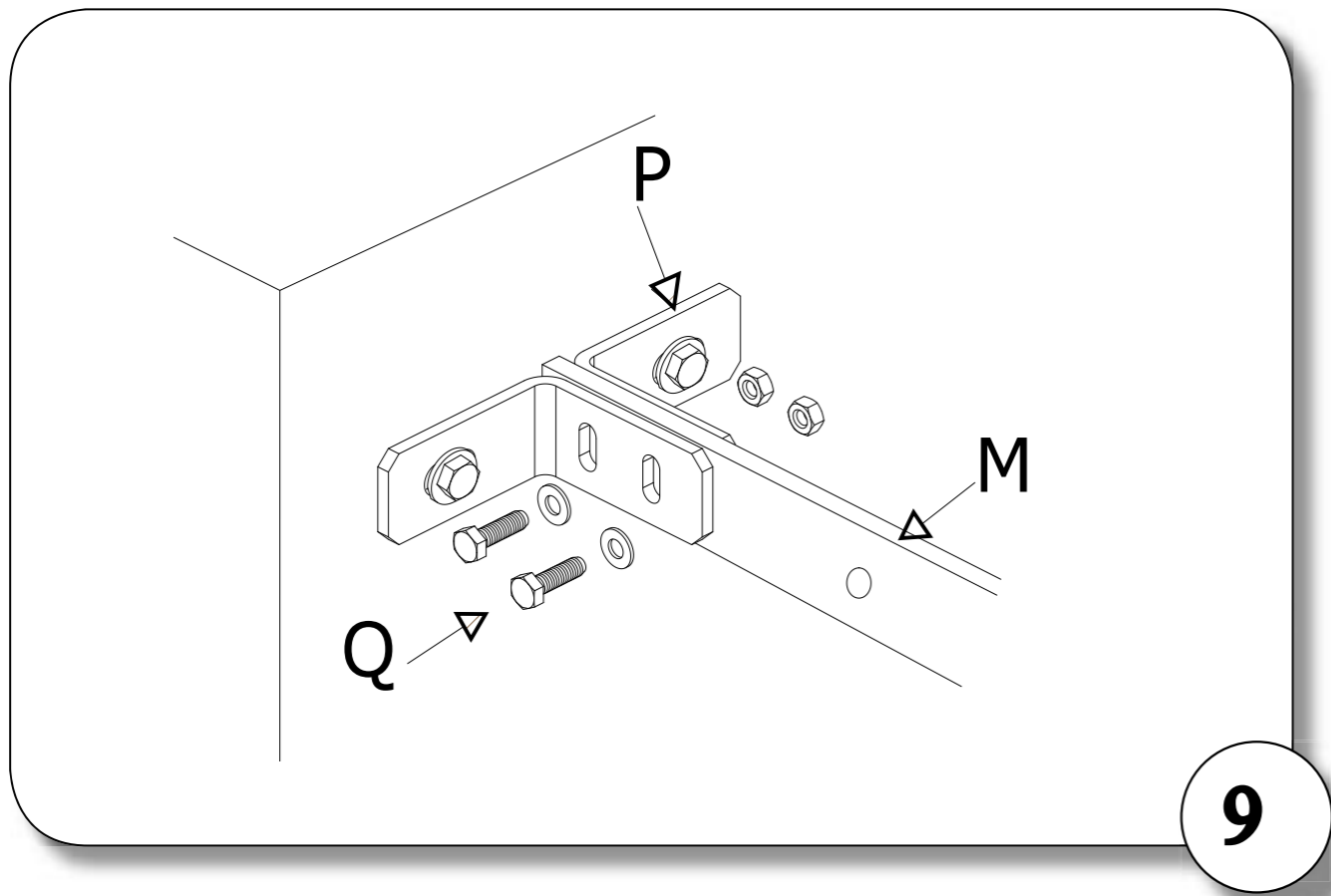

9

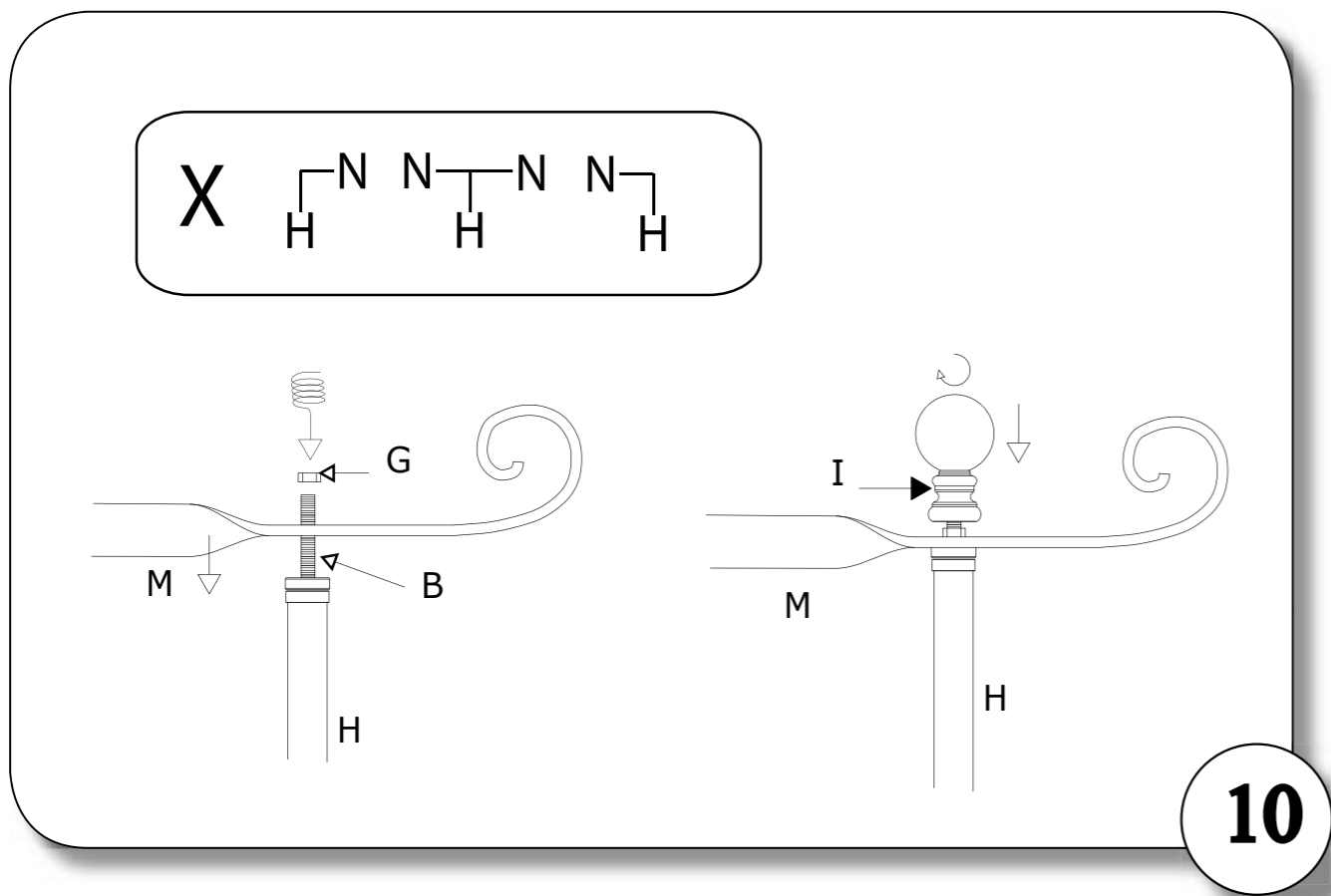

X H-N N-H N-N N-H

10

9

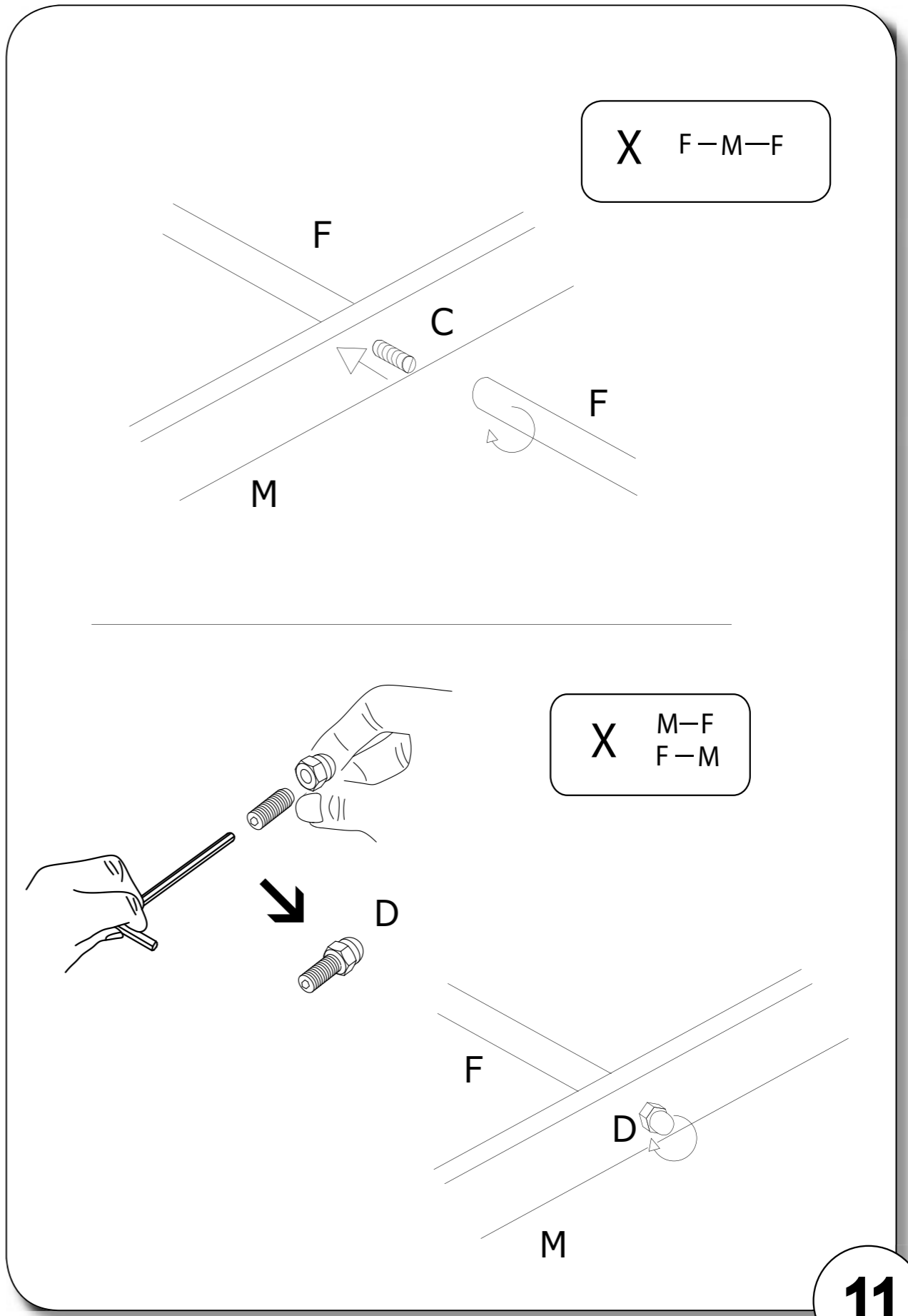

X F-M-F

X M-F
F-M

11

10

X art. PSW1C - PSW1EC
PSW2C - PSW2EC
PSW3C - PSW3EC

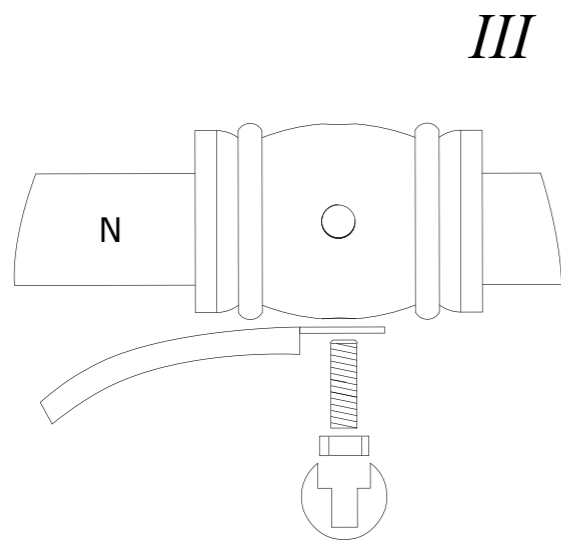
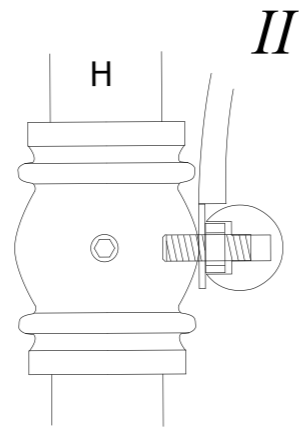
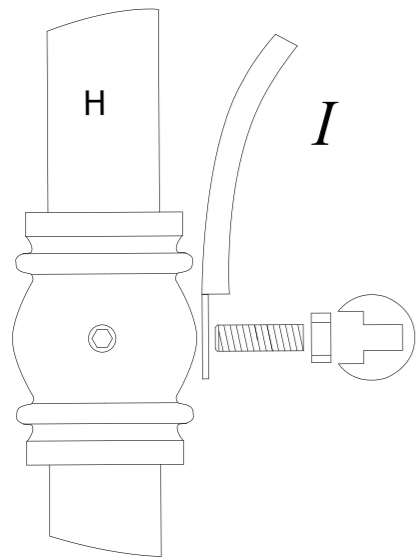
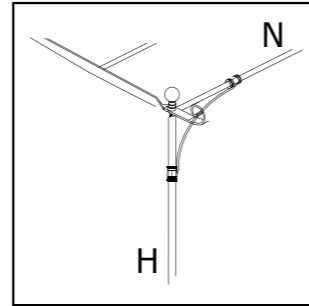

12

optional

ART.: CO135
ART.: CO220
ART.: CO320

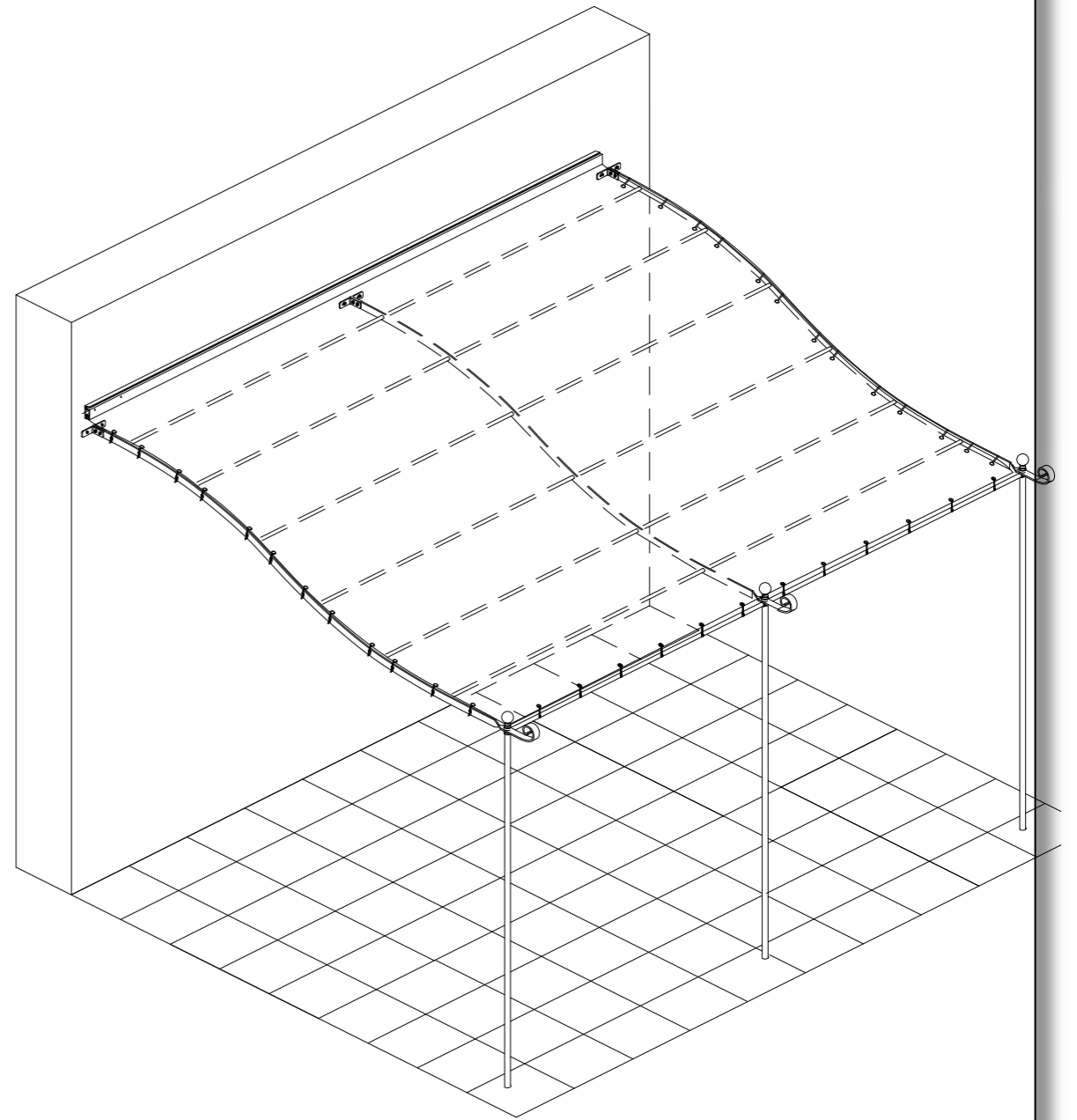

13

11

12

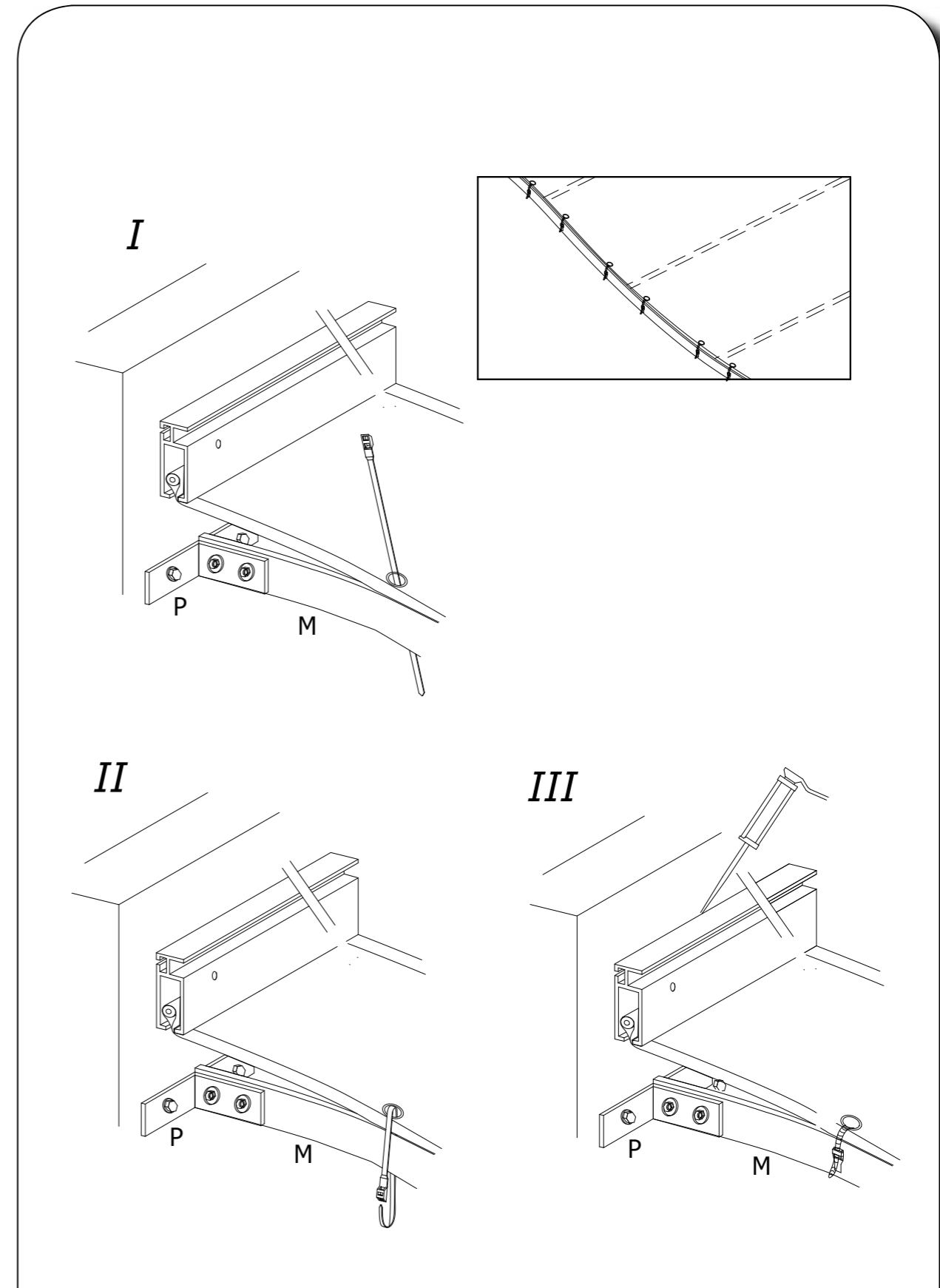
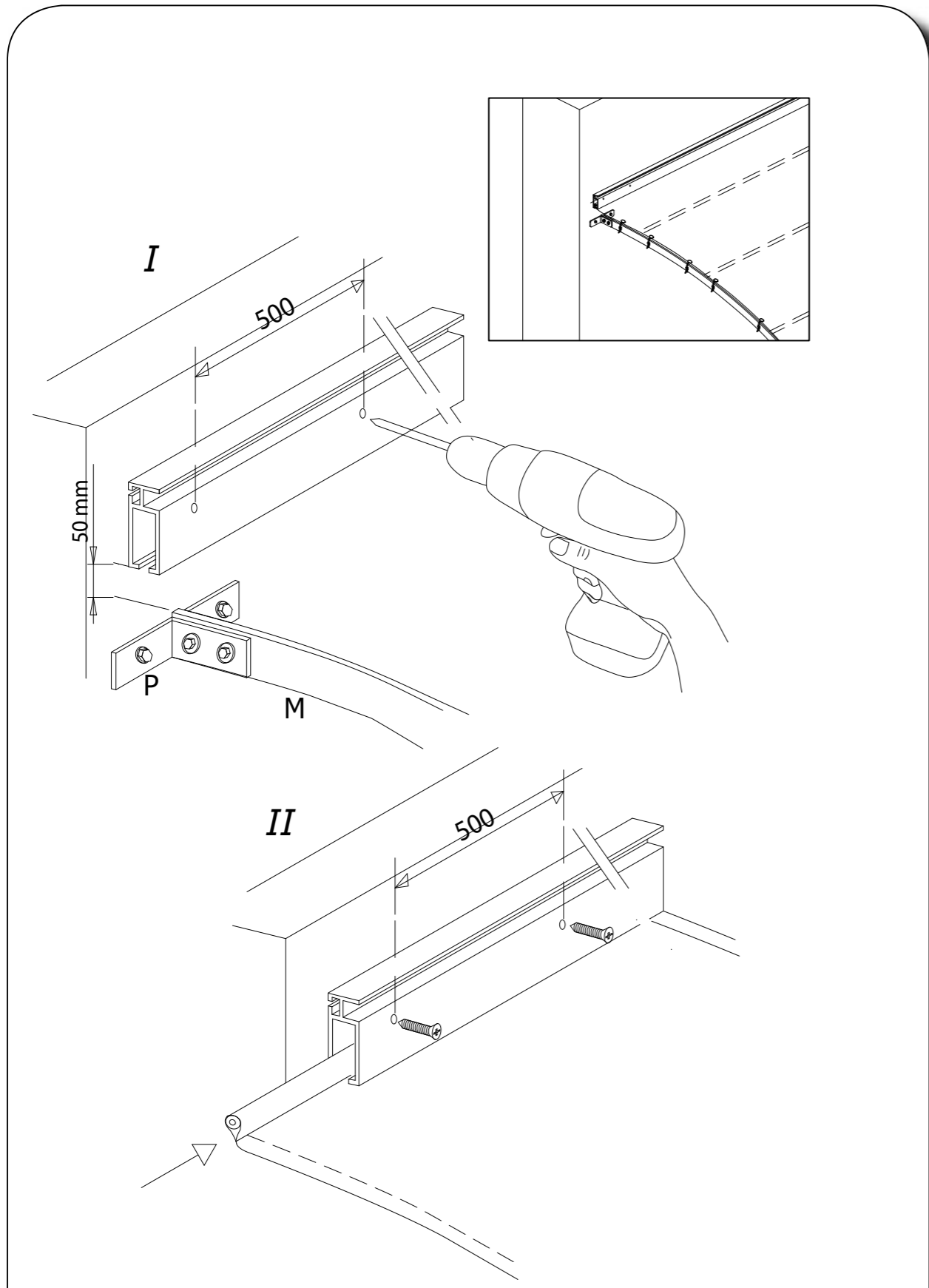

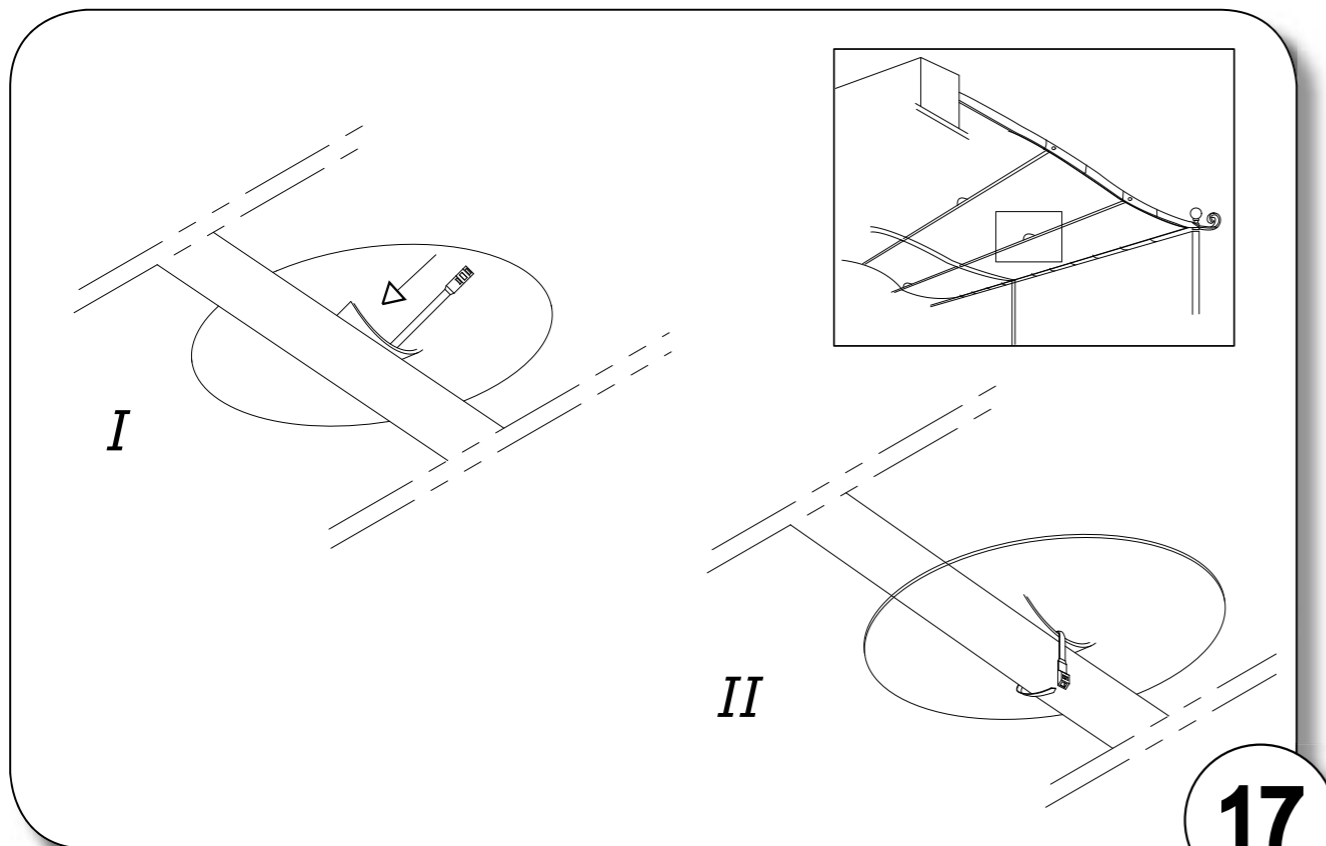

17

16

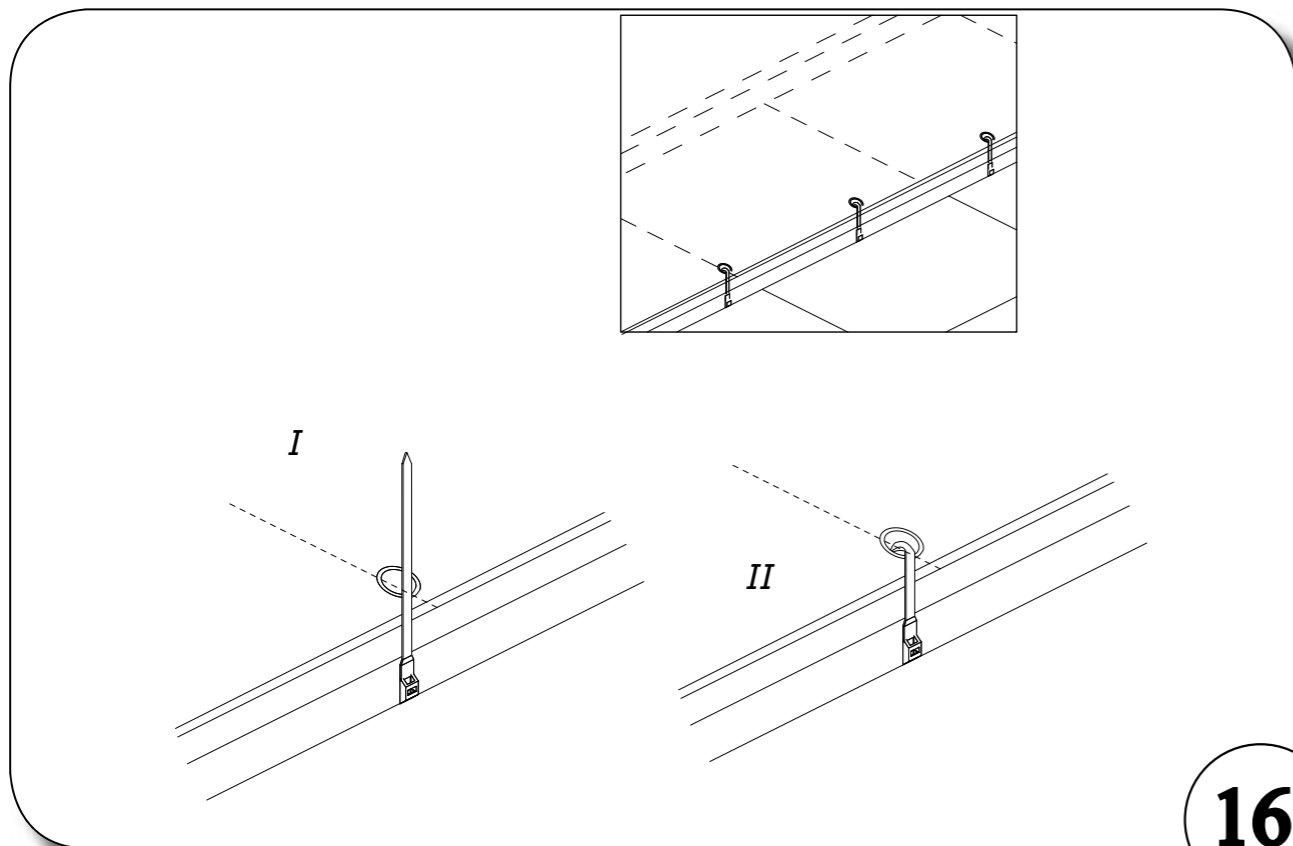

18

I La UNOPIU' S.p.a. declina ogni responsabilità sull'uso e/o montaggio non corretto che viene fatto dei materiali venduti.

Tutte le verifiche urbanistiche, statiche e di sicurezza in funzione:

- del luogo di installazione;
- della validità degli appoggi (muri, parapetti, pavimenti, ringhiere) e del relativo sistema di fissaggio;
- dell'uso di coperture (policarbonato, legno e tela) in funzione della ventosità o del carico neve delle zone di installazione, dovranno essere comunque verificate da un tecnico locale.

D UNOPIU' S.p.a. haftet nicht für Fehler bei der Montage od. für nicht bestimmungsgemäßen Gebrauch der verkauften Artikel.

Ein örtlicher Fachmann ist jedenfalls für die folgenden Überprüfungen in Anspruch zu nehmen.

- Überprüfung des Aufstellplatzes.
- Überprüfung der Stützpunkte (Wände, Brüstunge, Böden, Gelände) u. der Befestigungen.
- Überprüfung der Tragkraft.
- Überprüfung der Überdachungen (Polykarbonat, Holz, od. Stoffbespannungen), insbesondere in windigen und schneesicheren Gegenden.

F La Société UNOPIU' S.p.a. décline toute responsabilité concernant l'utilisation et/ou le montage incorrecte qui peut être fait du matériel vendu.

Toutes les vérifications concernant les normes d'urbanisme, la stabilité et la sécurité en fonction:

- du lieu de l'installation,
- de la stabilité des appuis (murs, parapets, sols, rampes) et des systèmes de fixation y afférent,
- de la charge des éventuelles armatures plancher/plafond,
- de l'utilisation de couvertures (polycarbonate, bois, toile) suivant l'intensité du vent et du poids de la neige sur les lieux de l'installation, devront être effectuées localement par un technicien local.

GB UNOPIU' S.p.a. refuses all responsibility for the incorrect use or assembly of the purchased items. A local technician should make all the surveys concerning city planning, statics and security with relation to

- the instalment area;
- the consistency of the supports (supporting walls, parapets, floors, balustrades) and relative fixing devices;
- the capacity of the floors, if there are;
- the use of coverings or roofings (polycarbonate, wood and canvas) according to the local wind strength or snow load.

E UNOPIU' S.p.a. no se asume ninguna responsabilidad por el uso incorrecto o montaje erróneo de los productos vendidos.

La verificación de los datos relativos a las normas urbanísticas, estáticas y de seguridad en función:

- del lugar donde se instalarán las estructuras;
- de la solidez de los puntos de apoyo (muros, pisos, parapetos, barandas) y de los específicos sistemas de fijación;
- de la resistencia del entresuelo;
- del uso de las cubiertas (policarbonato, madera, lona) de acuerdo con la fuerza del viento y las sobrecargas de nieve admitidas en la zona.

tendrá que ser realizada por un perito local, inclusive cuando nuestro departamento técnico les haya enviado un proyecto.

P A UNOPIU' declina qualquer responsabilidade pela utilização e/ou montagem incorrecta efectuada nos materiais vendidos.
Todas as verificações urbanísticas, estáticas e de segurança em função do local de instalação;
da validade dos apoios (paredes, parapeitos, pavimentos, corrimões) e do respectivo sistema de fixação;
da utilização de coberturas (policarbonato, madeira e tela) em função do vento ou da carga de neve das zonas de instalação, devem ser efectuadas por um técnico local.

NL UNOPIU' wijst alle aansprakelijkheid af in geval van een onjuist gebruik en/of montage van de verkochte materialen.
Alle stedenbouwkundige, veiligheids- en stabiliteitscontroles met betrekking tot: de installatieplaats;
de effectiviteit van de ondersteuning (muren, balustrades, vloeren, leuning) en het betreffende bevestigingssysteem;
de toepassing van afdekkingen (van polycarbonaat, hout en doek) op grond van de winderigheid of van de sneeuwbelasting in de installatiezone, moeten in alle gevallen door een plaatselijke technicus worden gecontroleerd.