

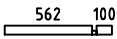

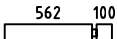





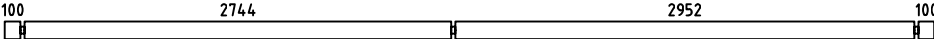
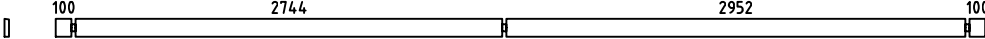
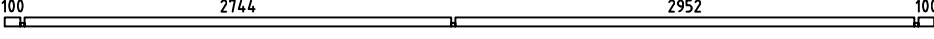
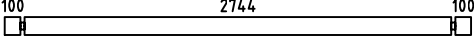
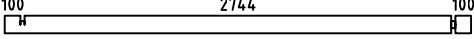
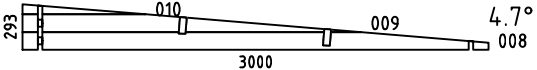
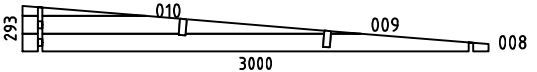
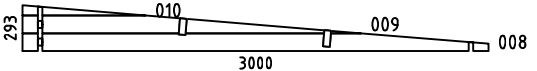

Utrecht 2

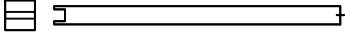
Pos	Specification-Spezifikation-Specificatie	St.	Profile (mm)	Length (mm)
001		2	28x57	690
002		32	28x114	690
003		16	28x114	315
004		16	28x114	5980
005		2	28x114	5980
006		1	28x57	5980
007		32	28x114	3000
011		1	28x114	3000
WA-1		1		
WB-1		1		
WC-1		1		
PR1		2	44x114	5980
DP-1	Roof board-Dachbrett-Dakplank 	68	88x18	3250
	-POST 85x85 	1		2005
L-1	Eave Board-Traufenblende-Afdekplank 	2	18x120	3290
L-2	Eave Slat-Traufenleiste-Afdekljst 	2	40x18	3290
L-3	Facia Board-Giebelblende-Gevelplank 	4	18x120	3008
L-4	Facia Slat-Giebelleiste-Gevelljst 	4	40x18	3008
	Adjustable foot-Stellfuß+Schrauben 4x50 4stück für Post 	1		
	Double Door Set-Doppeltür Satz-Dubbele Deur Set 	1		
	Nail-Nagel-Spijker 1.2x20 	15	1.2x20	
Kood	Materjal	File	Utrecht 2.dwg	Leht 1/2

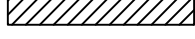
TOTAL: 15.63 m²

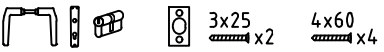

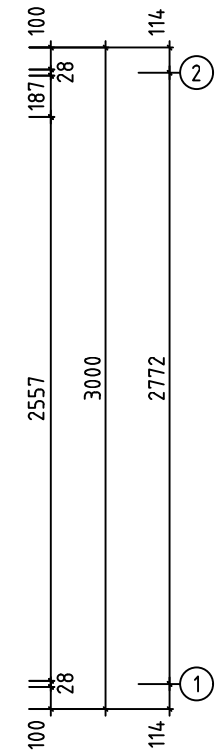
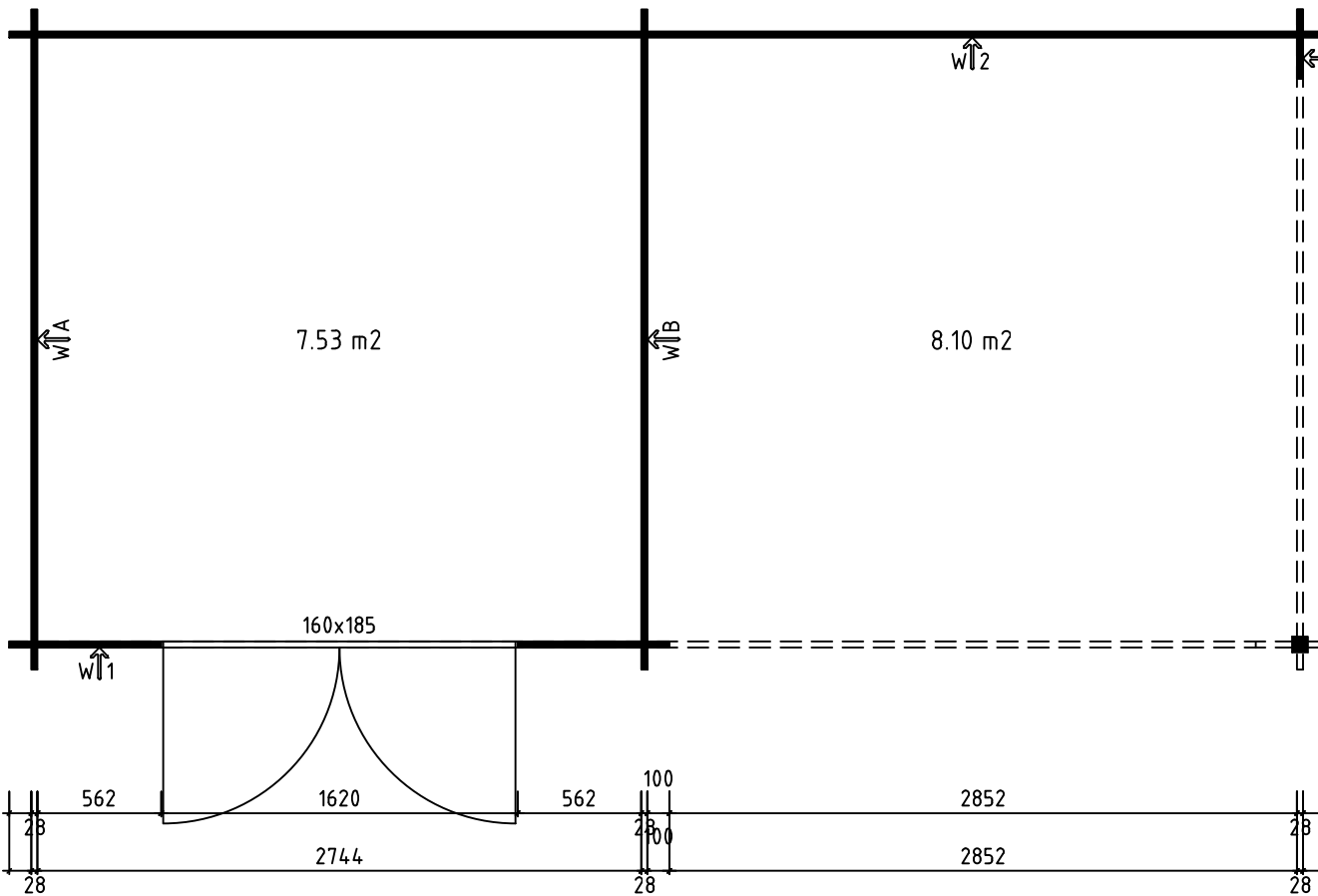
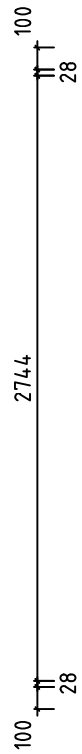
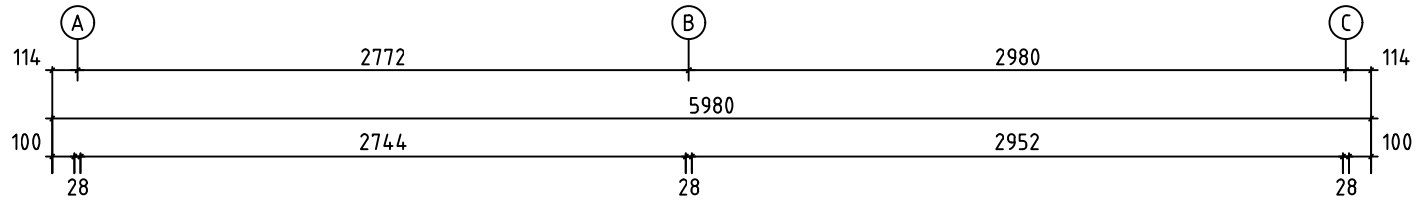
Model	Utrecht 2	Page	
Client		Scale	1:30
Material	28x114mm	Date	11.04.2019
Company		File	Utrecht 2.dwg

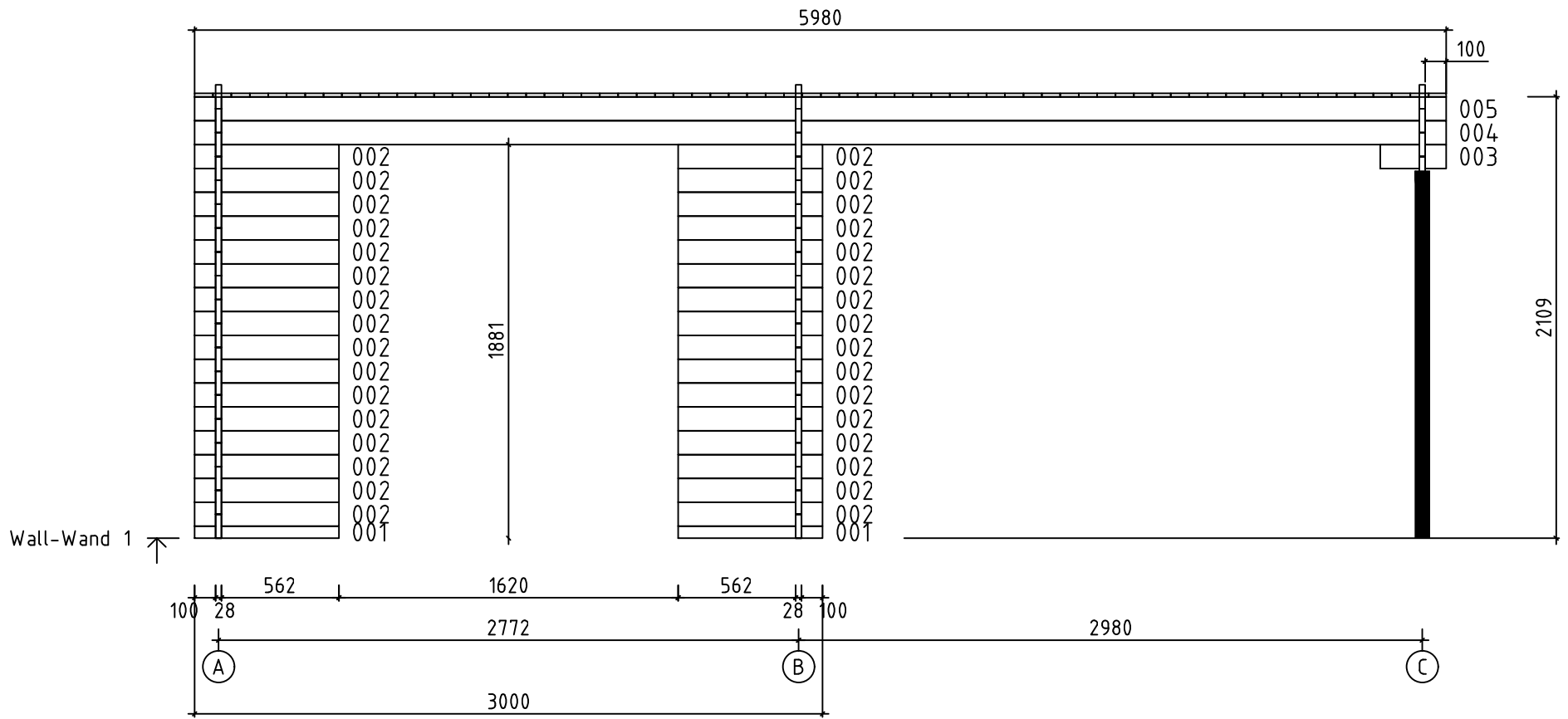

Model	Utrecht 2	Page	5
Client		Scale	1:30
Material	2.8x11.4	Date	11.04.2019
Company		File	Utrecht 2.dwg

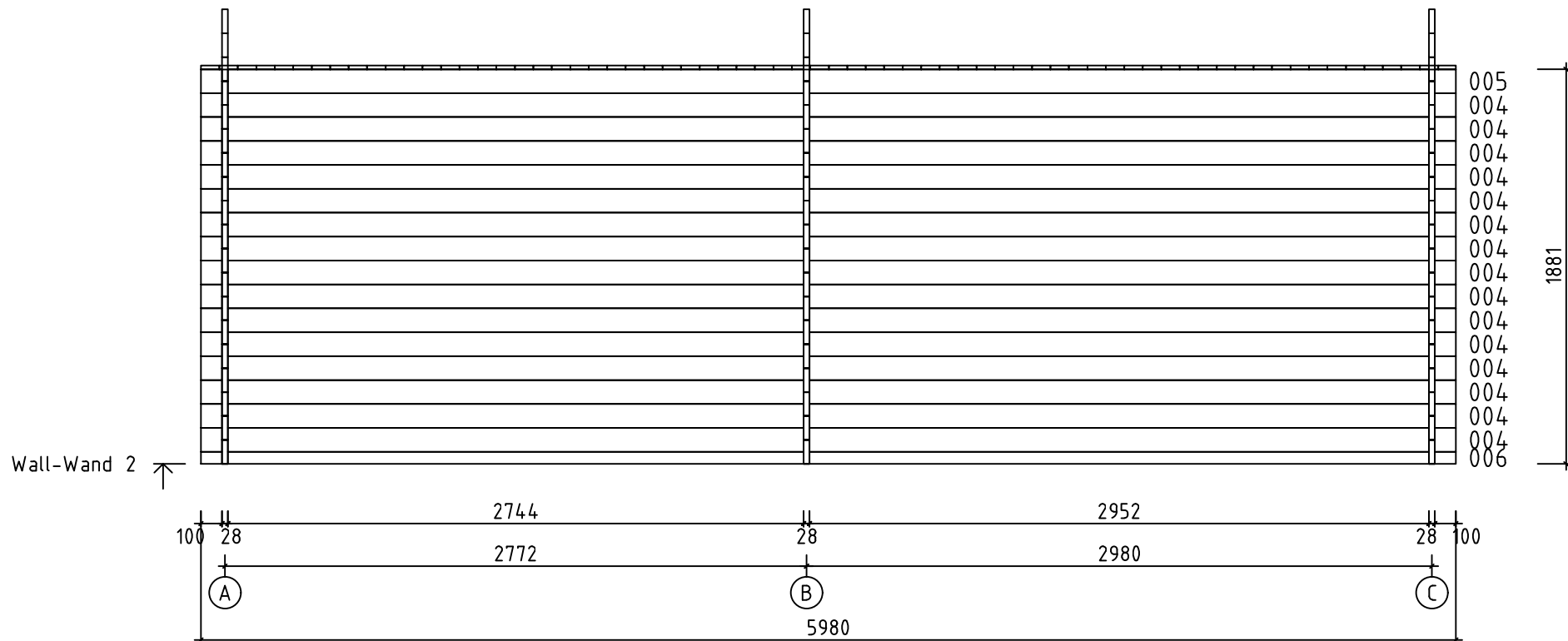

Model	Utrecht 2	Page	6
Client		Scale	1:30
Material	2.8x11.4	Date	11.04.2019
Company		File	Utrecht 2.dwg

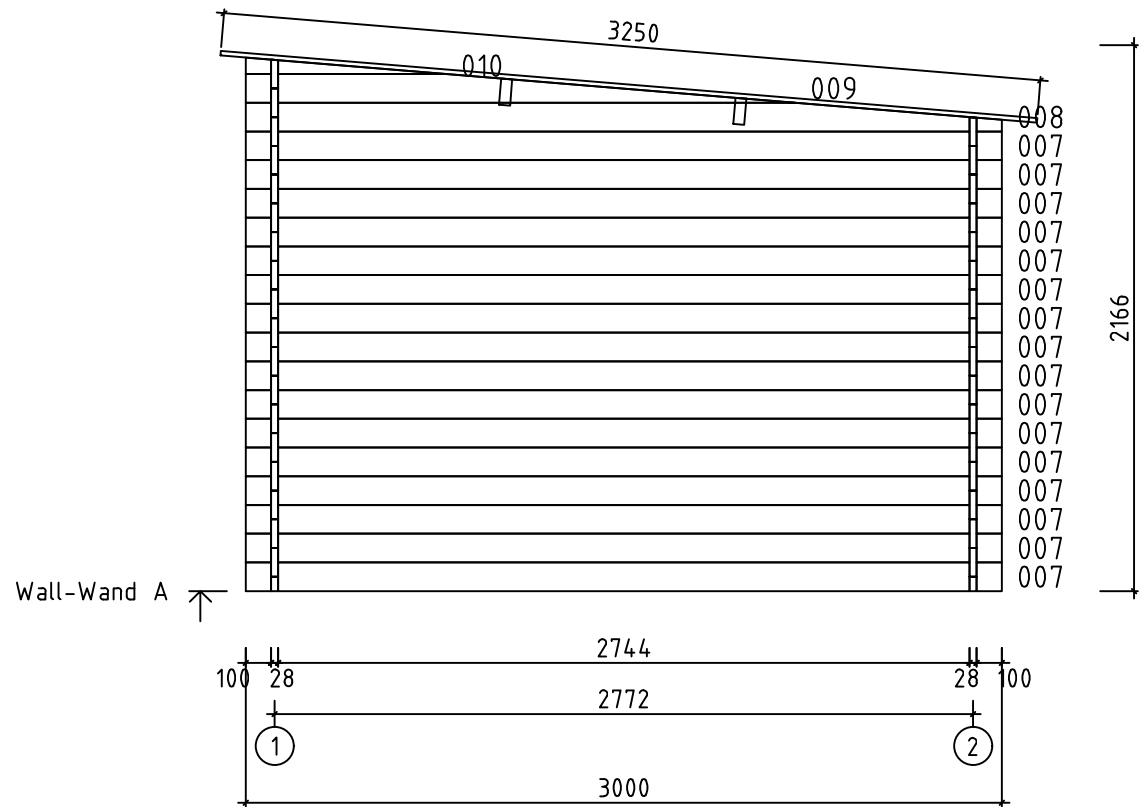

Model	Utrecht 2	Page	2
Client		Scale	1:30
Material	2.8x11.4	Date	11.04.2019
Company		File	Utrecht 2.dwg

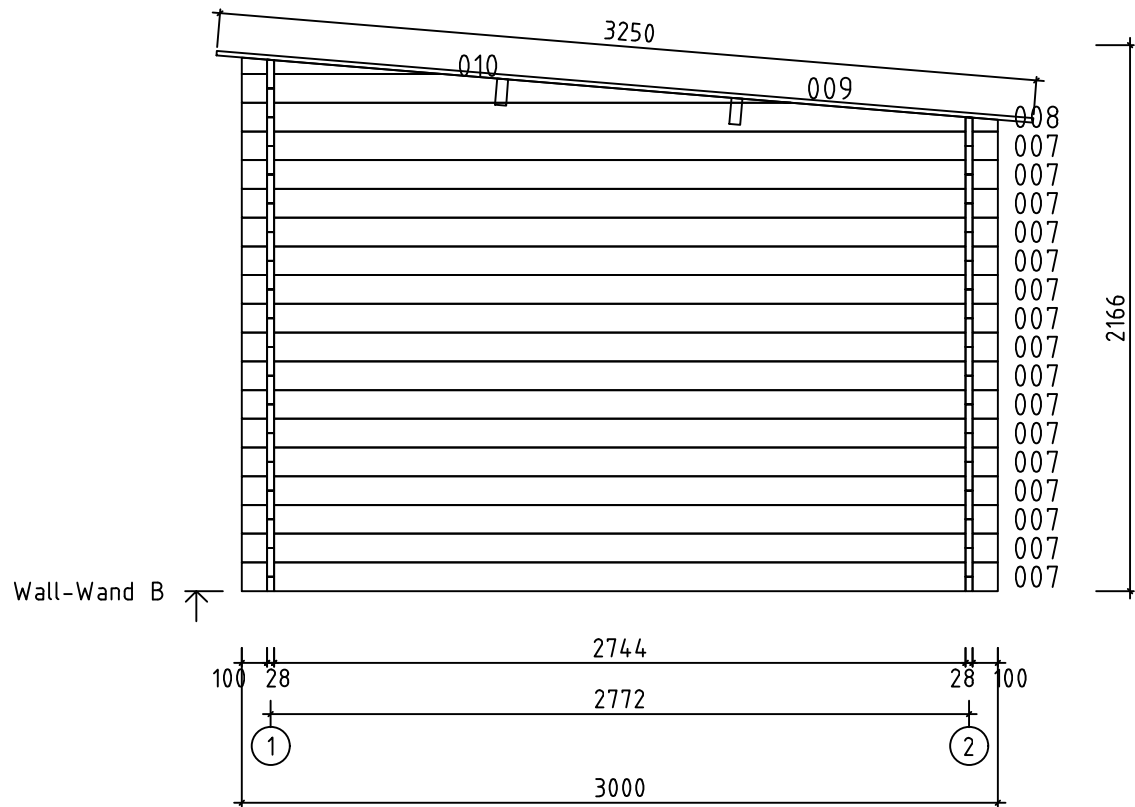

Model	Utrecht 2	Page	3
Client		Scale	1:30
Material	2.8x11.4	Date	11.04.2019
Company		File	Utrecht 2.dwg

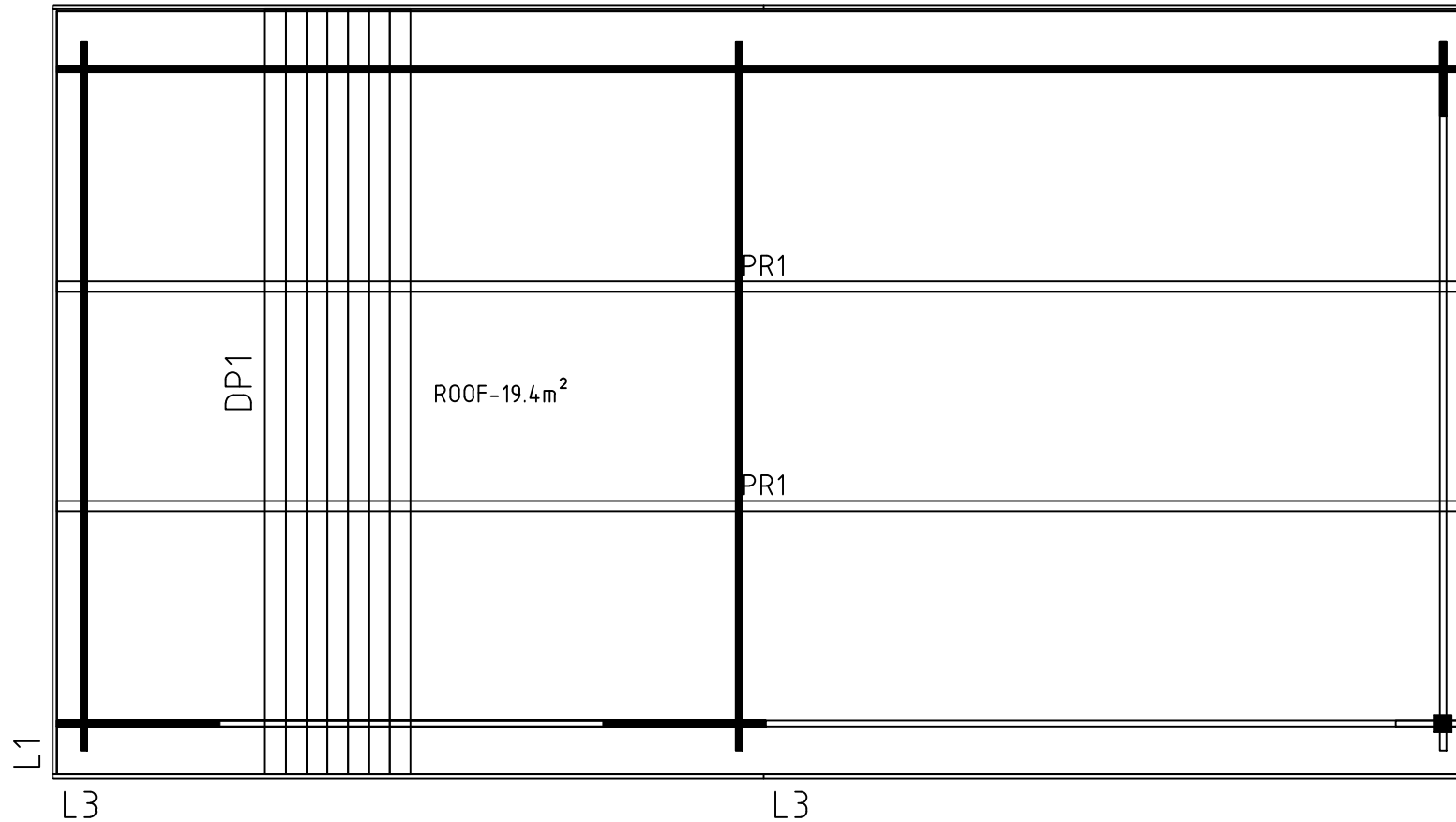
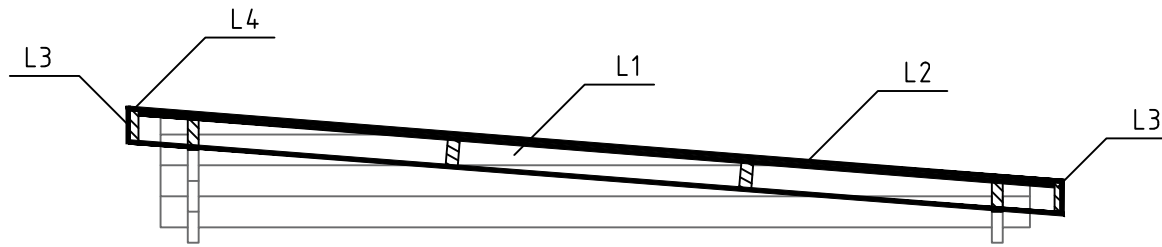

Model	Utrecht 2	Page	
Client		Scale	1:30
Material	28x114mm	Date	11.04.2019
Company		File	Utrecht 2.dwg

The guide is illustrative. This guide is not project specification.
 Der Leitfaden ist illustrativ. Dieser Leitfaden ist keine Projektspezifikation.
 De gids is illustratief. Deze gids is geen projectspecificatie.

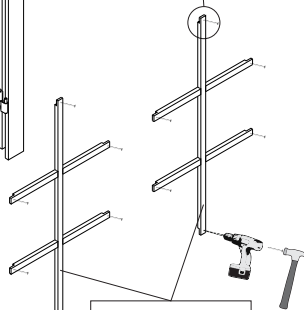
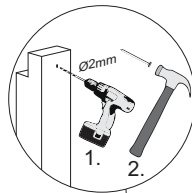
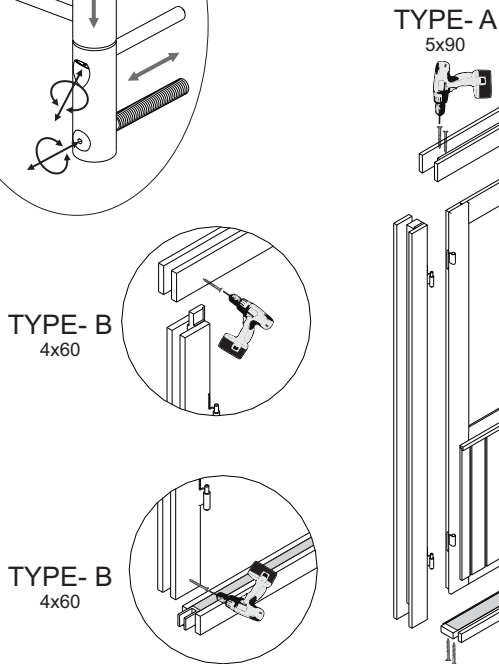
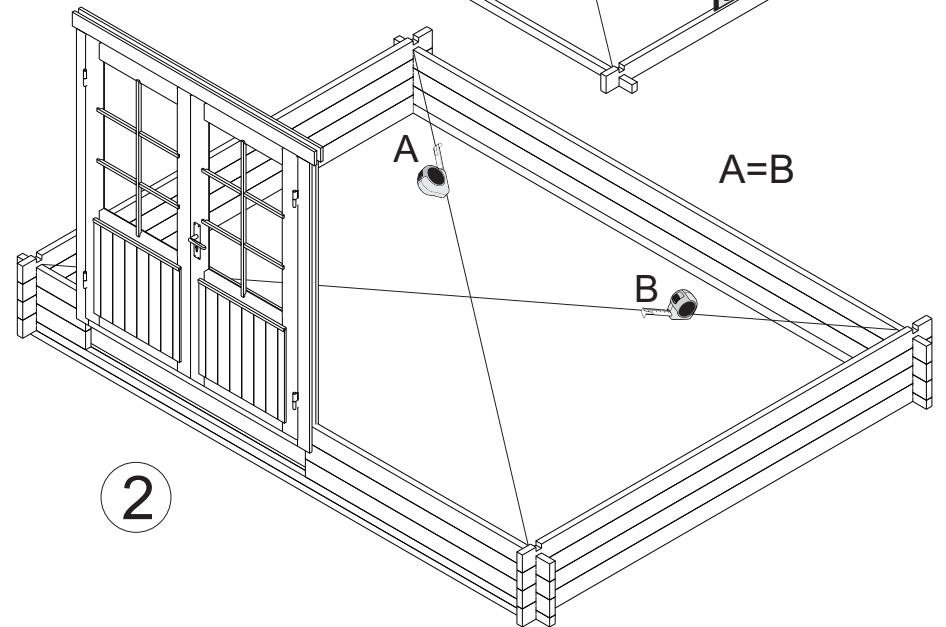
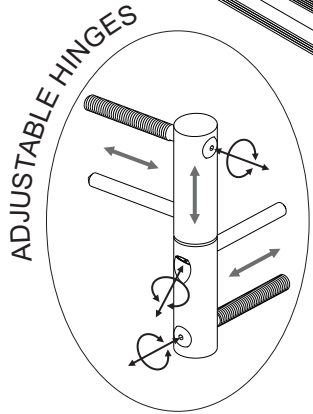
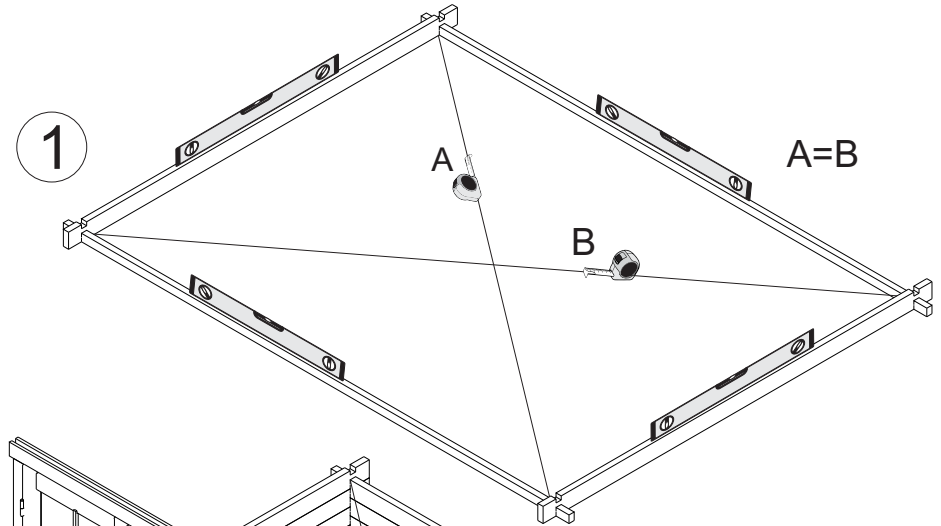
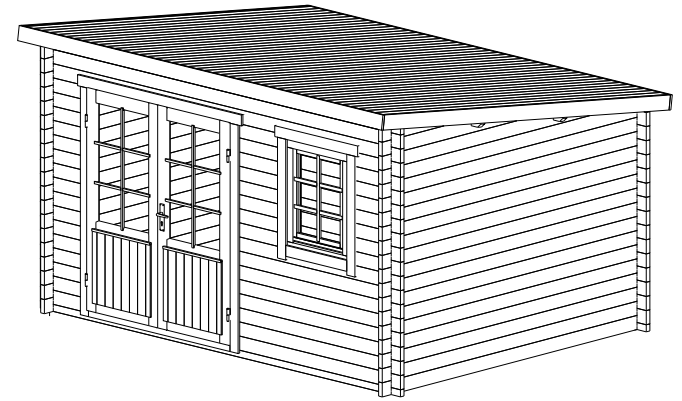
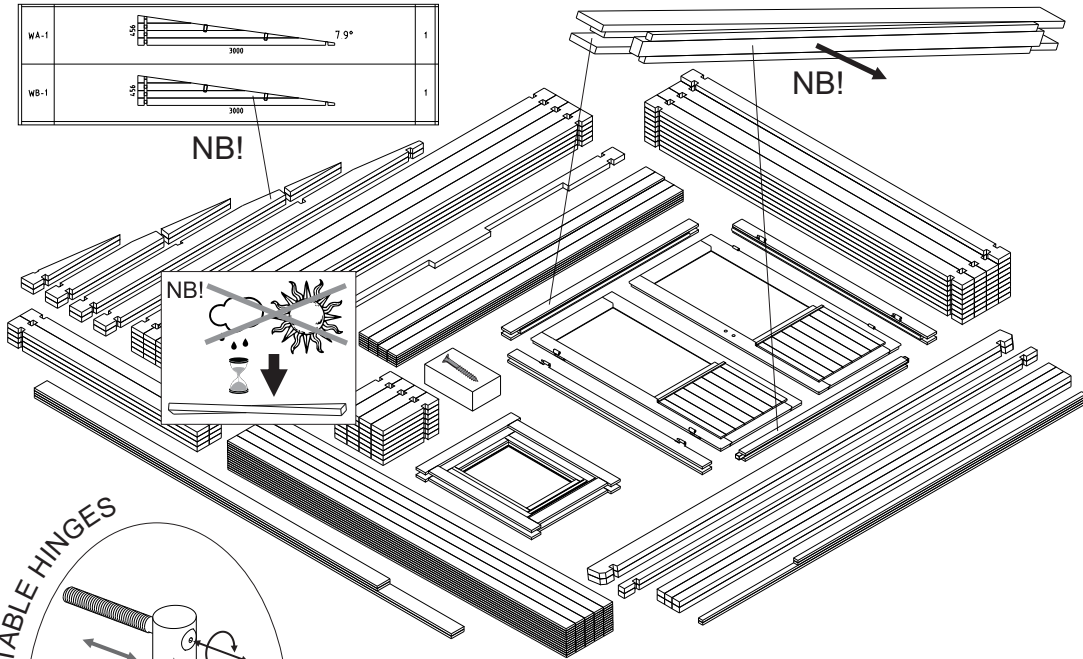
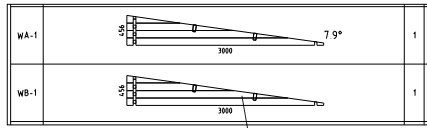

OPTIONS!

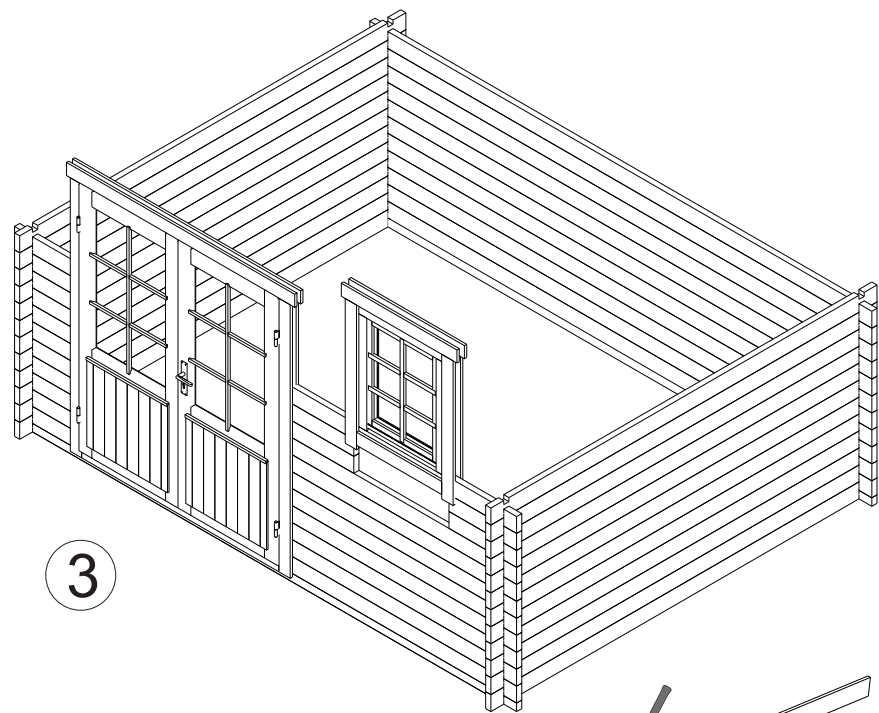

4

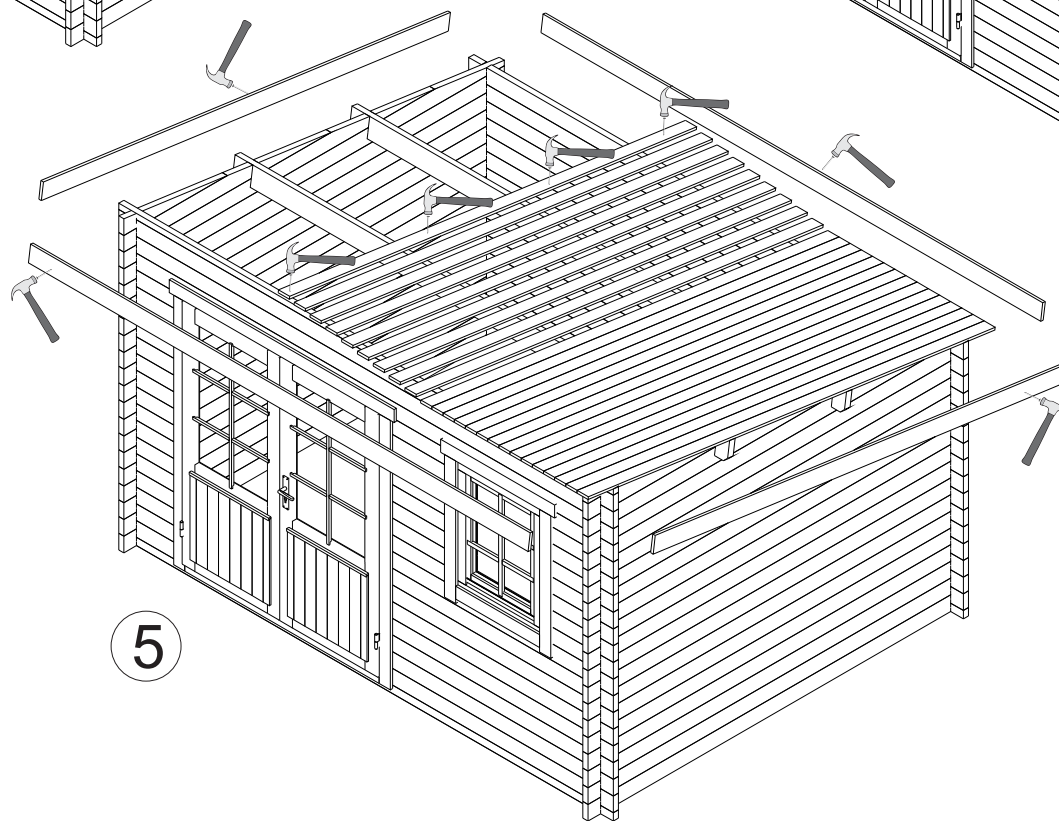
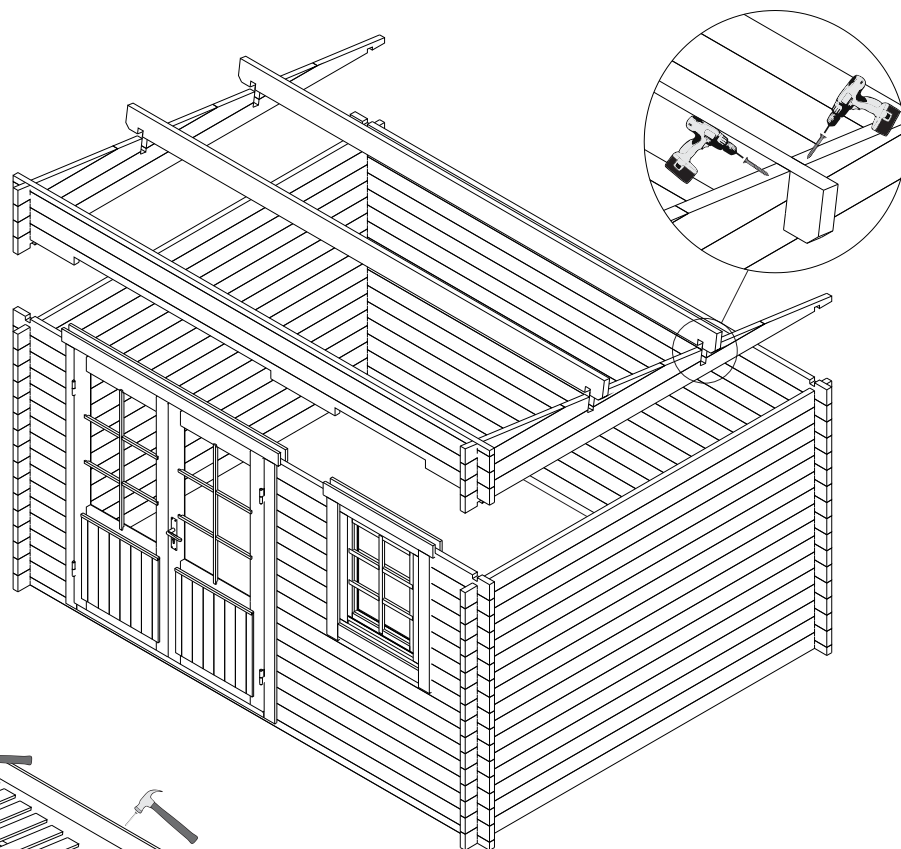

Cutting support post / Schneiden der Stützpfeiler

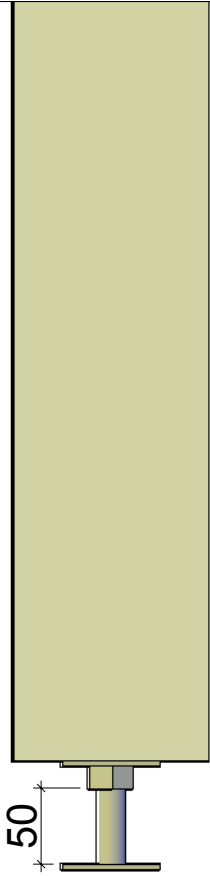

- * Adjustment space for post support should be at least 50mm.
- * Einstellraum für die Pfostenstütze muss mindestens 50mm sein.

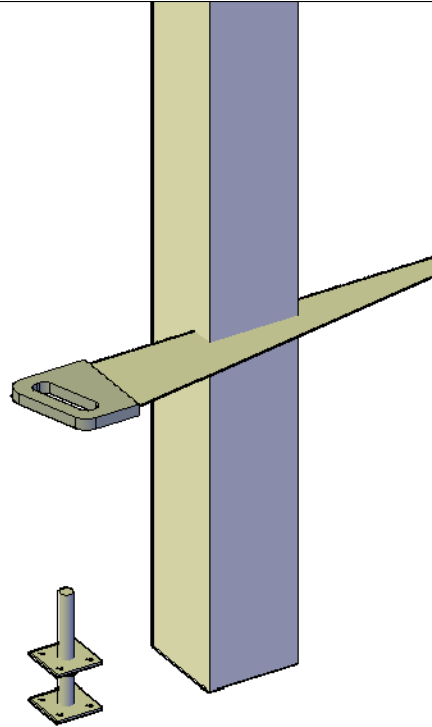

- * Support post has extra length for various conditions. Must be sawn to suitable length on spot considering local conditions.
- * Stützpfeiler hat extra Länge für verschiedene Bedingungen. Muss vor Ort unter Berücksichtigung der örtlichen Gegebenheiten zu einer geeigneten Länge gesägt werden.

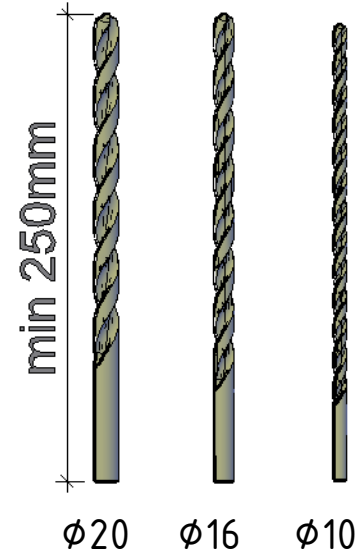
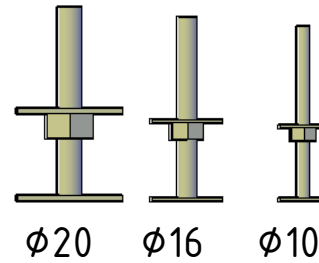

- * In some cases you need to drill a new hole for a post support. Find a matching drill bit.
- * In einigen Fällen müssen Sie ein neues Loch für die Pfostenstütze bohren. Finden Sie hier den passenden Bohrer.

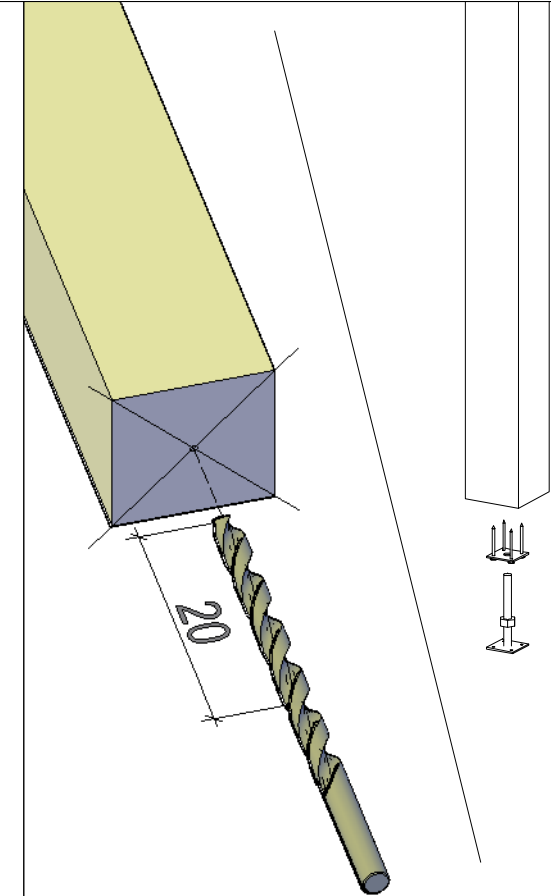

- * Mark the center of the post and drill a new 20cm deep hole. Continue building.
- * Markieren Sie die Mitte des Pfeilers und bohren Sie ein neues 20cm tiefes Loch. Danach mit Aufbau weiter machen.